

# Chalmers Book of Instructions



Thirty-six  
Model 17



# OWNER'S REPORT

191

**T**HIS blank properly filled in and mailed immediately after receipt of your car to the Chalmers Motor Company, Detroit, Michigan, will constitute a registration of your address at the factory and will insure your receiving copies of all circular letters, instructions, suggestions and general communications of interest, as well as many courtesies upon the part of the Company. Please cover the following items:

Car No. (see plate on frame beneath front floor board) \_\_\_\_\_

Does car operate satisfactorily? \_\_\_\_\_

Motor No. (see top of fly-wheel case) \_\_\_\_\_

From whom purchased \_\_\_\_\_

Address (of seller) \_\_\_\_\_

Finish of car \_\_\_\_\_

## REMARKS

\_\_\_\_\_  
\_\_\_\_\_  
\_\_\_\_\_

Name of owner \_\_\_\_\_ Occupation \_\_\_\_\_

Street and number \_\_\_\_\_

City \_\_\_\_\_ County \_\_\_\_\_ State \_\_\_\_\_

Be sure to lubricate your machine thoroughly before putting it into service





*This monogram on the  
radiator stands for all  
you can ask in a motor car*

All Chalmers Dealers carry  
in stock repair parts for  
Chalmers cars. Chalmers  
owners are requested to  
purchase all such parts  
from the nearest Chalmers  
dealer. Such a course will  
greatly facilitate service to  
owners in case of emergency

Engravings and Printing by  
Peninsular Engraving Company  
Detroit



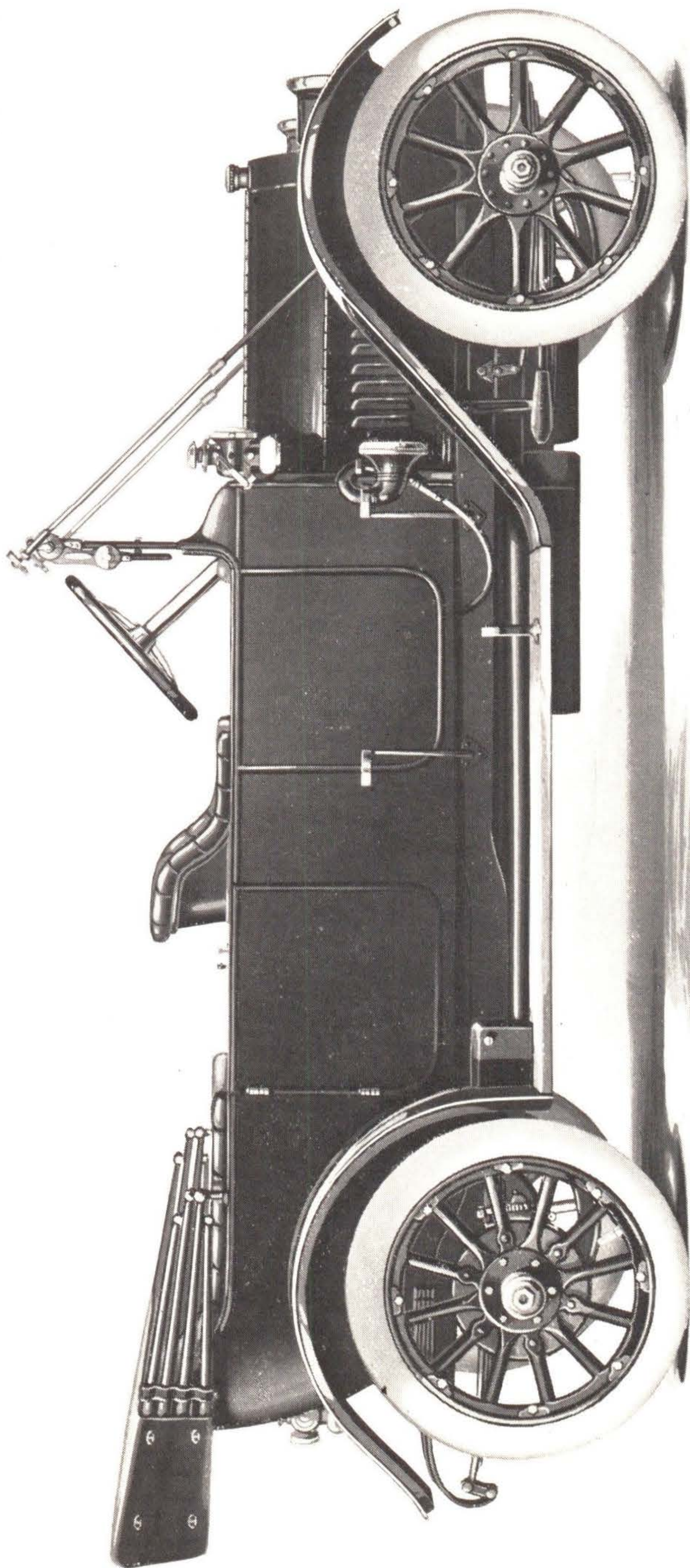

Chalmers "Thirty-six" Touring Car



# Book *of* Instructions

## Chalmers "Thirty-six"

Model 17

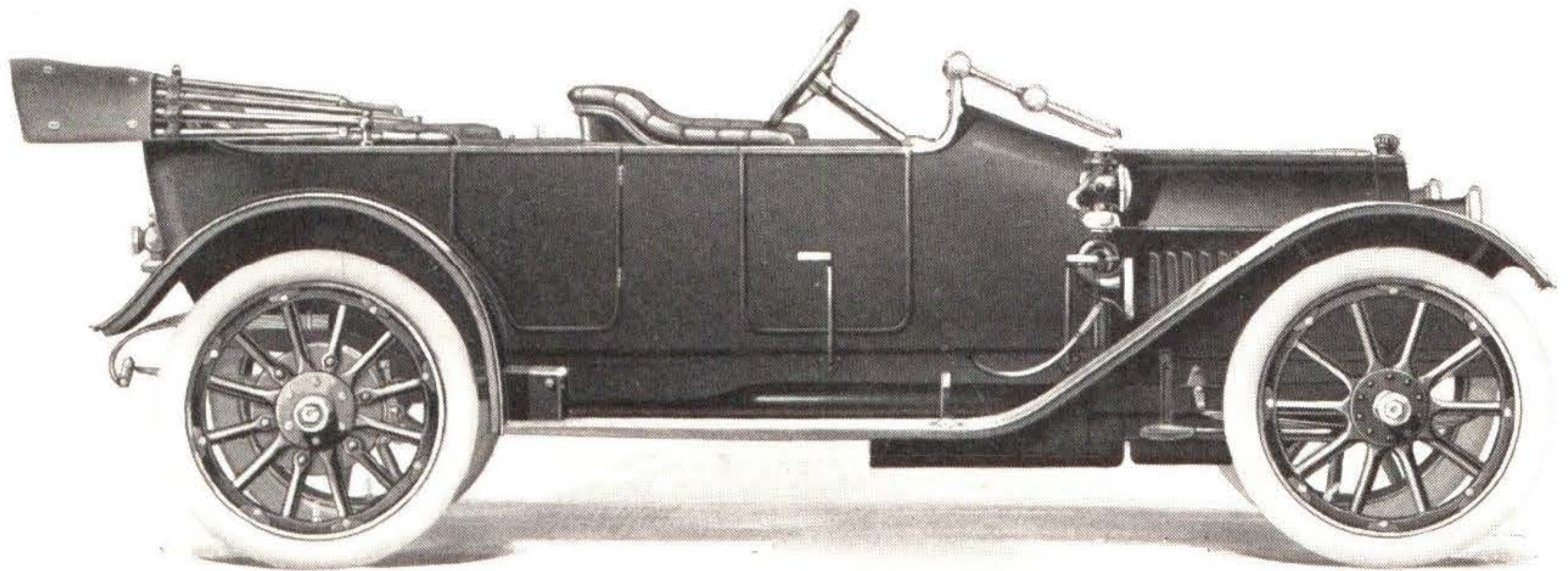

Chalmers "Thirty-six" Torpedo

Chalmers Motor Company

Detroit, Michigan



## Table of Contents

	Page
Introduction.....	5
Repairs and Correspondence.....	6
General Directions for Operation.....	7
Care of Car—	
Directions for Lubrication.....	13
Semi-Monthly Inspection.....	15
Principle of Four-cycle Gasoline Motor.....	17
The Five Systems of a Motor Car.....	19
Gasoline System.....	21
Ignition System.....	27
Water Circulation System.....	33
Lubrication System.....	35
Power Transmission System.....	39
Compressed Air Starting System.....	43
Electric Lighting System.....	49
Proper Care of Motor.....	53
Running Gear.....	57
Cold Weather Procedure.....	59
Troubles.....	60
Driving Suggestions.....	63
Miscellaneous Suggestions.....	65
Index.....	66

## Illustrations

	Page
Chalmers "Thirty-six" Touring Car.....	Frontispiece
Chalmers "Thirty-six" Torpedo.....	Title Page
Dash Arrangement of Chalmers "Thirty-six".....	11
Plan View Chalmers "Thirty-six" Chassis (Fig. 1).....	12
Diagram of Four Strokes, Four-cycle Motor (Figs. 2-5).....	16
Gasoline System—Carburetor (Fig. 6).....	20
Gasoline Pressure Pump (Fig. 7).....	26
Ignition System (Fig. 8).....	28
Water Circulation System (Fig. 9).....	32
Lubrication System—Oil Pump (Fig. 10).....	34
Motor—Top and Bottom Views (Fig. 11).....	36
Power Transmission System (Fig. 12).....	38
Transmission and Clutch (Fig. 13).....	40
Movements of Gear Shift Lever (Fig. 14).....	42
Air Pressure Starting Mechanism (Fig. 15).....	44
Diagrammatic Views, Self-starter Distributor (Fig. 16).....	46
Self-starter Four-cylinder Air Pump, Cylinder Valve, Push Valve (Fig. 17).....	48
Electric Lighting System (Fig. 18).....	50
Dynamo of Electric Lighting System (Fig. 19).....	52
Motor—Exhaust Side and Rear Views (Fig. 20).....	54
Motor—Intake Side and Front Views (Fig. 21).....	56
Brake Construction (Fig. 22).....	58



# Introduction

**W**HILE it is the object of the Chalmers Motor Company to build Chalmers cars as nearly trouble-proof as expert mechanics, the most modern automobile machinery and rigid inspection can make them, complete freedom from trouble can come only through a thorough understanding of the car and proper care of its various parts.

It must be remembered that a motor car is a machine, and like all machines, it will not work properly if misused. The handling of a car, how to lubricate it and how to keep it clean, are things which must be understood if satisfaction is to be assured.

The object, then, of this book of instructions is to help Chalmers owners to get the most satisfaction with the least trouble from their cars by giving them a proper understanding of the principles upon which a motor car operates and as thorough a knowledge as possible of how to care for a car. No effort has been made to tell how to take the car apart. The car properly cared for will require very little taking apart; and when such an operation is necessary we want you to have as little as possible to do with the work. This is a book of directions, not a repair man's manual.

If anything should happen to necessitate tearing down any part of your Chalmers car we advise you to take it to a competent repair man. It is cheaper in the end. But if you do have to make any repairs yourself, do not act hastily. Study out what may be wrong before you begin to unfasten things. At all times the Service Division of the Chalmers Motor Company stands ready to furnish you information, advice and assistance. This department is maintained entirely for the benefit of Chalmers owners. Its experts will be glad to give you assistance in every difficulty. Please feel free to write the Service Division regarding any point about which you may desire help.

We advise every owner of a Chalmers "Thirty-six" to read this book carefully before putting his car in operation. You may understand motor cars but you cannot know too much about the particular car you are driving. New owners are especially requested to read the entire book thoroughly before putting into practice the "Directions for Operation."

**Chalmers Motor Company**  
 Detroit, Mich.



## Repairs & Correspondence

It is our effort to build Chalmers cars so that repairs will be unnecessary. Accidents, lack of proper care or hard usage, sometimes, however, necessitate replacements.

To facilitate the making of needed replacements the Chalmers Motor Company has established repair parts stock depots in Kansas City and San Francisco, in addition to the stock carried at the factory and by Chalmers dealers. By writing or telegraphing to either of these points repair parts can be secured with all possible expediency. The following are the addresses of the branch repair stock depots:

Chalmers Motor Company Stock Depot,  
1524 Grand Avenue,  
Kansas City, Mo.

Chalmers Motor Company Stock Depot,  
515 Van Ness Avenue,  
San Francisco, Cal.

When possible, parts should be ordered through Chalmers dealers, otherwise they will be sent C. O. D. unless cash accompanies the order. We are compelled to make this rule to avoid opening a lot of small accounts on our books.

To insure prompt attention to correspondence, whether relating to the shipment of repairs or not, always give your car number (which will be found upon the frame beneath the front floor board) and the type of body.

Please write a separate letter about each subject. Mail is distributed to different departments at the factory according to subjects covered and if one letter refers to several topics it may take a long time for it to make the rounds.

Correspondence should be addressed to the company, not to individuals.



# General Directions for Operation

## Putting the Car in Service

Fill radiator with clean water.

Directions on Page 33.

Fill gasoline tank.

Directions on Page 21. See that shut-off cock in gasoline pipe is open. (See Figure 6, Page 20.)

Fill motor crank case with oil to level of top try cock (See Figure 10, Page 34).

Directions on Page 35.

Be sure that clutch (See Page 39) and transmission (See Page 13), differential and driving gears (See Page 14) and universal joints (See Page 14) are well lubricated.

Put oil in oil holes and turn down grease cups.

The car when shipped from the factory is sufficiently lubricated for at least fifteen miles of road work. We do not, however, assume responsibility for any damage due to lack of attention to this matter on the part of the owner. Complete oiling directions are given beginning Page 13. The motor oiling system is described in the section on "Lubrication System," Page 35.

## Before Starting the Motor

See that the gear shifting lever is in neutral position.

Full instructions regarding this lever are given on Page 41.

Advance throttle lever (the longer lever at top of steering wheel) about one inch from base of quadrant.

In some conditions of weather gasoline may not vaporize quickly. At such times explosions will not start readily. In such instances advance throttle a little more.

Set spark lever (the shorter lever at top of steering wheel), at the base of the quadrant.

Never advance spark lever in starting as the motor will be likely to "back fire." If the crank is being used for starting there is always danger of injury from a "kick-back" of the crank.

After setting spark and throttle levers in proper positions and ascertaining that gear shift lever is in neutral position, turn ignition switch on dash (See Figure 8, Page 28) to the point marked "B" (Battery).



Then push dash button of self-starter firmly with the foot. (See Figure 15, Page 44.) Keep foot on push button of self-starter until explosions occur in the motor. Remove foot from self-starter button; throw ignition switch on dash over to point marked "M" (magneto); advance spark lever two-thirds of the way up quadrant; retard throttle lever to point where motor does not "race."

Should self-starter fail to work, the motor is probably on "dead center." In such case turn the starting crank about two inches from right to left, then again push dash button of self-starter.

When crank is used to start motor, follow directions as above.

Then give starting crank a brisk pull upward with left hand. Motor should start on half turn; if not, see Page 60.

### In Case the Battery has "Run Down" Motor May Be Started on the Magneto

Advance throttle lever about one inch from base of quadrant.

Advance spark lever about two-thirds of the way up quadrant.

Turn dash ignition switch to point marked "M."

When starting motor on magneto it will be found necessary to hold the foot on dash button of starter for a longer time than when starting on the battery.

If crank is used to start motor on magneto, "spin" crank rapidly in clock-wise direction.

To turn dash ignition switch to "M."

### When the Motor Starts Do Not Forget

(It will be in this position already if motor has been started on magneto.)

To advance spark lever about two-thirds up quadrant.

(It will be in this position already if motor has been started on magneto.)

To close throttle until motor runs slowly.

### To Put Car in Motion

After taking seat at steering wheel release hand brake. (See Figure 14, Page 42.)

(Never forget to release this brake.)

Disengage the clutch by pushing the pedal at left with left foot. (See illustration of Dash arrangement on Page 11).



Increase the speed of the motor slightly.

This may be done by advancing the hand throttle lever a short way along the quadrant, or by pressing on the accelerator pedal (See Page 11) with the right foot. An inexperienced operator will probably obtain better results in shifting gears by keeping the hand throttle lever part way open—say one to one and a half inches from base of quadrant—during the shifting operation. After having mastered the use of the gear shifting lever the skillful driver will learn to control the motor speed during gear shifting, by means of the accelerator pedal. (See Page 63.)

The gear shift quadrant on the Chalmers "Thirty-six" is of the sliding gate type with four speeds forward and reverse. (See Figure 14, Page 42.)

**A spring catch operating from the top of the gear shifting lever prevents accidental shifting of the gears into reverse. In starting the car be sure that the hand is not pressing down the button at the top of the gear shifting lever.**

Pull the gear shifting lever in toward you and push it quickly forward into first speed position.

(Explanation of the gear shifting mechanism will be found on Pages 39 and 41.)

Let clutch in gently by gradually releasing pressure on foot pedal.

The car will now move forward. Allow it to gain speed.

Again disengage the clutch.

Pull gear shifting lever straight back through neutral into second speed position.

This shift should be made quickly. If made slowly or timidly the gears will probably not engage at once. The car will then lose momentum and it will be necessary to return to first speed.

Open throttle to increase the speed of the motor, using either throttle lever at top of steering wheel or foot accelerator, and engage the clutch. As stated above, the beginner will probably obtain the best results by leaving the hand throttle lever part way open while shifting gears.

Allow the car to gain headway to about ten or twelve miles an hour.

Again disengage the clutch.



Push gear shifting lever forward to neutral position, then over to the right; then with a quick movement, forward into third speed position.

This operation takes but an instant when the driver has learned to shift gears with confidence. This shift should always be made quickly to avoid clashing the gears.

Again accelerate speed of motor and engage clutch.

Again disengage clutch.

Pull gear shifting lever straight back into fourth or high speed position.

Let the clutch in slowly.

Increase the speed of the motor until the car is traveling at the desired rate of speed, by pressing with the right foot on the accelerator pedal or by advancing the hand throttle lever. Keep the spark lever advanced as far as possible up the quadrant without causing the motor to "knock."

### To Change Back Into Lower Speed

If, in going up a steep hill or through heavy going, the car is slowed until the motor labors, the gear should be shifted at once into the next lower speed. For ordinary grades it will not be necessary to go below third speed. On steep hills change to second or first speed according to the requirements.

Disengage clutch; quickly move the gear shifting lever back into the next lower speed, being careful not to allow the car to lose momentum in shifting gears; let the clutch in gently and open the throttle to gain speed.

### To Stop the Car

Push clutch pedal with left foot until clutch is disengaged. Then apply service brake by gradually pushing down brake pedal (the one at the right) with right foot.

At the same time reduce the motor speed by moving the hand throttle lever backward or releasing the pressure on the foot accelerator.

When the car is stopped, while still holding out the clutch, place the gear shifting lever in neutral position and then let in the clutch.

If the car is to be left standing, set the hand brake.



## To Reverse the Car

Push out the clutch. Push down on the button at top of gear shifting lever and move lever from neutral position in toward you to slot at extreme left. Then pull it backward into reverse speed position. Let clutch in gently.

Never attempt to go into reverse while the car is still moving forward, or into a forward speed while the car is moving backward.

## To Stop the Motor

Turn the dash ignition switch to "off" position.

Close throttle entirely before stopping motor.

Closing the throttle when stopping motor gives best results in use of Self-starter.

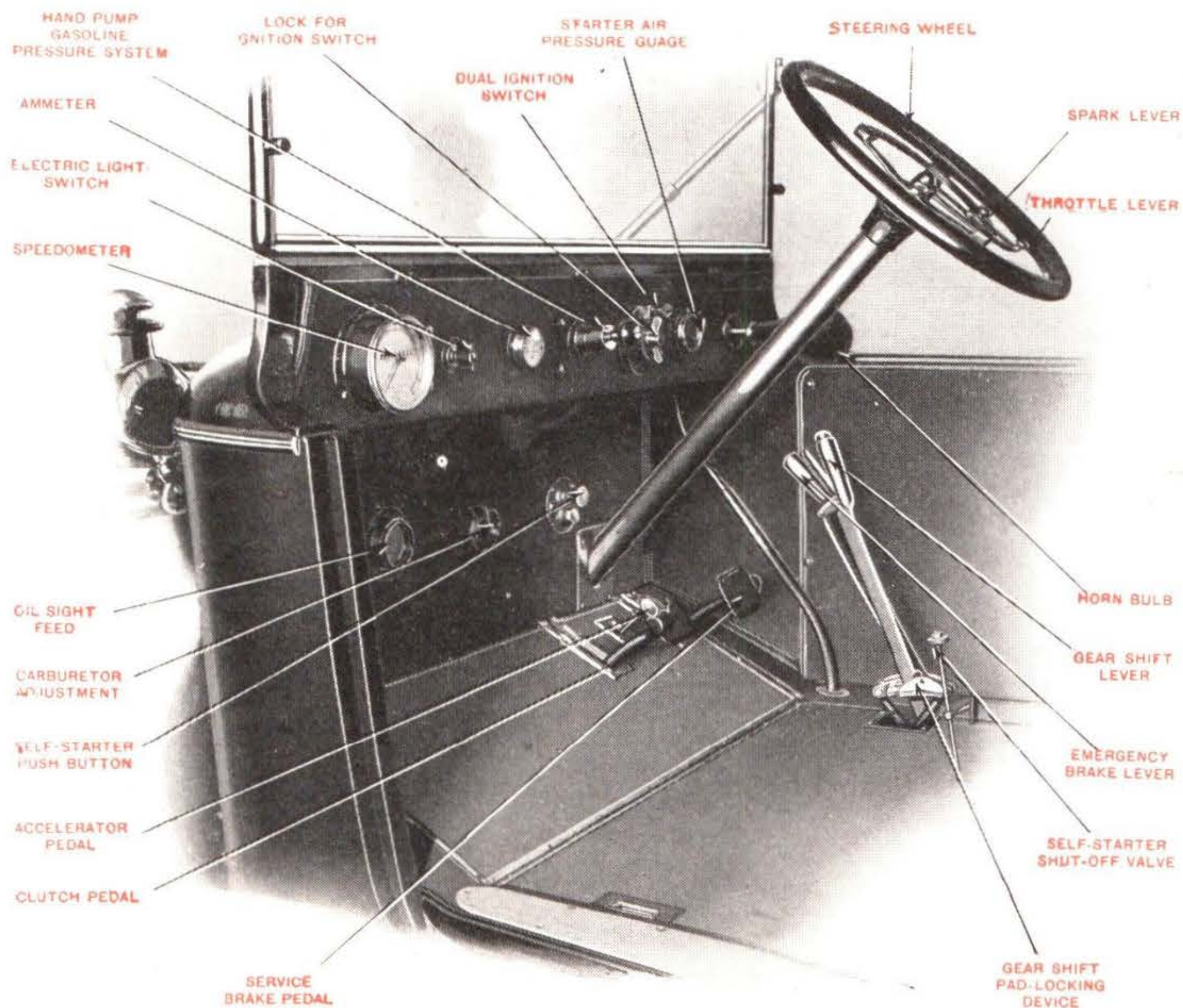

The Chalmers "Thirty-six" Dash Arrangement







# Care of the Car

## Directions for Lubrication

### Oiling the Motor

A complete description of the motor oiling system and its operation, with instructions for its care and adjustment, will be found beginning on page 35.

### Every Day Car is in Use, or Every 100 Miles

PART	QUANTITY	LUBRICANT
Crank case.	Keep oil at level of top try cock.	Motor oil.
Steering knuckle. grease cups.	One complete turn.	Cup grease.
Steering cross rod grease cups.	One complete turn.	Cup grease.
All spring bolt grease cups.	Two complete turns.	Cup grease.
Eccentric bushing.	10 or 15 drops.	Motor oil.
Wheel hub oilers.	10 drops.	Motor oil.

### Twice a Week, or About Every 200 Miles

PART	QUANTITY	LUBRICANT
Fan hub bearing.	Few drops.	Motor oil.
Pump shaft grease cup.	Two complete turns.	Cup grease.
Rocker arms.	Thoroughly.	Motor oil.
Steering gear case oiler.	Fill.	Motor oil.
Steering gear case grease cup.	Two complete turns.	Cup grease.
Steering wheel oil hole.	8 or 10 drops.	Motor oil.
Steering column.	10 or 15 drops.	Motor oil.
Self-starter distributor grease cup.	One complete turn.	Cup grease.

### Every Week, or About Every 300 Miles

PART	QUANTITY	LUBRICANT
Starting crank bearing.	10 drops.	Motor oil.
Inlet valve covers.	Tablespoon.	Motor oil.
Spark and throttle shafts.	Few drops.	Motor oil.
Control bracket bearings.	Thoroughly.	Motor oil.
Transmission case.	Enough to cover lower shaft.	600 "W" steam cylinder oil.
Clutch casing.	Should contain 1 qt. to 3 pints.	One-half motor oil— one-half kerosene.
Pedal fulcrum pin.	Thoroughly.	Motor oil.
Brake pull rods and connections.	Thoroughly.	Motor oil.



PART	QUANTITY	LUBRICANT
Self-starter pump	2 ounces	600 "W" steam cylinder oil.
Brake cross rod grease cups. (Inside frame.)	Two complete turns.	Cup grease.
Torque rod grease cups, front and rear.	Two complete turns.	Cup grease.
Brake shafts on rear wheels.	Thoroughly.	Motor oil.
Rear spring perch grease cups.	Two complete turns.	Cup grease.

### Twice a Month, or Every 500 Miles

PART	QUANTITY	LUBRICANT
Magneto bearings (3 oil holes.)	3 or 4 drops each.	High grade light machine oil.
Clutch case.	Drain, flush with kerosene, refill with 1 quart to 3 pints.	One-half motor oil— one-half kerosene.

### Every Month, or Every 1000 Miles

PART	QUANTITY	LUBRICANT
Crank case.	Drain off dirty oil, clean oil screen, fill to level of top try cock.	Motor oil.
Gear shifting rod case.	Pack thoroughly.	Cup grease.
Reach rod boots.	Pack thoroughly.	Cup grease.
Spring leaves. (Jack up frame and pry leaves apart.)	Thoroughly.	Graphite grease.
Hup caps.	Pack thoroughly.	Cup grease.
Universal joints.	Remove grease hole plug and fill.	Cup grease.
Gasoline pressure hand pump.	4 or 5 drops.	Light machine oil.

### Every 2000 Miles

PART	QUANTITY	LUBRICANT
Differential housing.	3 pints.	A mixture of two-thirds grease and one-third motor oil.
Transmission case.	Drain thoroughly flush with kerosene, refill to cover lower shaft.	600 "W" steam cylinder oil.

Dynamo should be lubricated every 5000 miles. (See Page 49.)

### When Changing Tires

Put few drops oil on inside sliding ring of demountable rims to insure easy detaching.



# Semi-Monthly Inspection of Car

## Compression in Motor Cylinders

Test compression. For directions see page 53.

Inspect inlet valve cage and exhaust valve bonnets for possible compression leaks.

## Ignition System

Inspect wiring, terminals, spark plugs.

See that all connections are tight and insulation perfect.

## Water Circulation System

Inspect pump and connections for possible leaks; fan and fan belt; carburetor water connections.

## Gear Shifting Mechanism

Inspect levers, slide rods, etc.

## Brake Adjustment

See that service brakes and emergency brakes, both located on rear hubs, pull equally and do not drag.

## Steering Connections

Inspect steering connections for loose nuts and bolts.

## Springs

Keep spring clips tight.

Inspect spring bolts and hangers. Be sure rear spring perches are free to move on axle housing.

## Storage Battery

Test the battery for voltage.

If voltage drops to 5.40, have battery recharged. (See page 27.)

## Bolts

Tighten body and fender iron bolts.



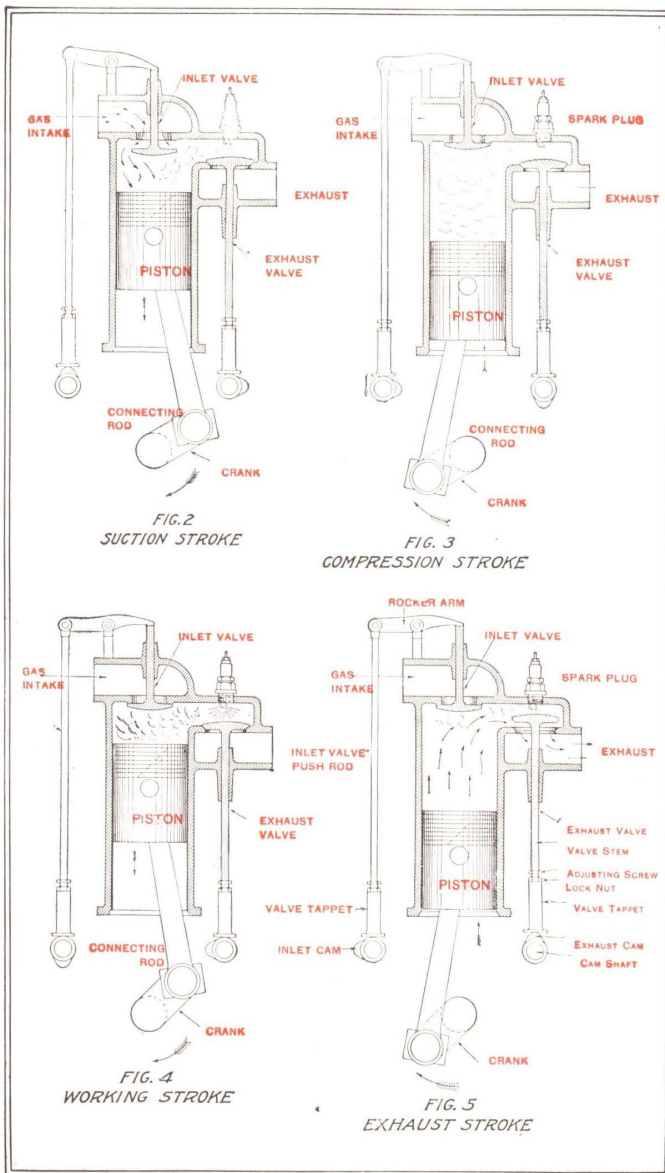

Diagram of the Four Strokes of a Four-cycle Motor

To make the illustration clearer, the inlet valves and exhaust valves are shown as if operated by separate cam shafts. In reality, both sets of valves on the Chalmers "Thirty-six" are operated by a single cam shaft at the left side of motor.



# Principle of Four-Cycle Gasoline Motor

The easiest way to understand the operation of a gasoline engine is to compare it with the shooting of an old-fashioned, muzzle-loading rifle. Both derive their power from the explosion of gases within a confined space. In the one case the explosion drives out a bullet. In the other case, it pushes upon a piston.

In shooting a gun the powder and bullets are put into the muzzle, and rammed down or compressed by a ram-rod, fired by a cap placed under the hammer, and finally the barrel is cleaned with a rag on the end of the ram-rod. Thus we have four steps:

- (1) Introduction of charge.
- (2) Compression of charge.
- (3) Explosion of charge.
- (4) Cleansing of barrel.

The same series of events takes place in the operation of a gas engine, each step corresponding with the stroke of the piston.

- |                                       |                     |
|---------------------------------------|---------------------|
| (1) Introduction of gas . . . . .     | Suction stroke.     |
| (2) Compression of gas . . . . .      | Compression stroke. |
| (3) Explosion of gas . . . . .        | Working stroke.     |
| (4) Removal of burned gases . . . . . | Exhaust stroke.     |

Carrying the comparison a little further, let us suppose we were able to connect the bullet with some sort of a rod so that its energy could be converted into rotary motion and used to turn a wheel. Then, instead of using all the force of the explosion to carry itself through the air, it would travel only a short distance, and would store up its energy in the revolving wheel. This is what happens when we have substituted for our bullet the piston of a gas engine. If now, we could supply a simple mechanism which would introduce and fire new charges at regular intervals, our wheel would be kept in motion and the power developed could be used for driving purposes. Thus we should have practically a single-cylinder gas engine.

The accompanying figures illustrate such an engine, showing the four strokes explained above.

Fig. 2, the "suction stroke," shows the introduction of gas into the cylinder. At the beginning of this stroke, the intake valve in the top of the cylinder opens, the exhaust valve at the side being closed. As the piston descends, gasoline vapor mixed with air is sucked into the cylinder just as water is drawn into a pump or syringe when you draw out the plunger.



As the piston begins to ascend ("compression stroke," Fig. 3) both intake and exhaust valves are closed. The piston traveling upward compresses the gas in the upper part of the cylinder, called the combustion chamber.

Just as the crank shaft passes over "dead center," the highest point in the piston's travel, an electric spark is discharged between the terminals of the spark plug (Fig. 4). This explodes the gas, pushing down the piston with great force. This is the "working stroke." During it the valves are, of course, closed.

At the end of the working stroke, the exhaust valve at the side of the motor opens (Fig. 5). The piston, forced up by the momentum of the crank shaft and flywheel, pushes out the burned gas through the exhaust valve and the piston is ready for a repetition of the four strokes. Such is the operation of every "four-cycle" motor.

It will be readily understood from the above that the "working stroke" occupies only one-quarter of the total operation of the motor, yet the three extra strokes are required to prepare the engine for a duplicate set of operations. If now we arrange four cylinders in a row to operate on the crank shaft, timing their explosions so that they will follow in suitable order, we shall have four "working strokes" following each other so closely that power is being exerted on the crank shaft practically all the time. This is what we have in a four-cylinder motor, such as the Chalmers "Thirty-six."



# The Five Systems of a Motor Car

The engine of an automobile is, of course, the most important part of the entire machine. But in order that the power of the engine may be applied to driving the automobile along the roads, various other factors are necessary. The mechanism of a motor car may be divided into five different systems, each of which is explained separately in the pages following. These systems correspond in a general way, with the different systems—circulation, respiration, nervous, etc.—of the human body.

1. In the motor car there is a respiration or breathing system—gasoline vapor is the car's breath of life.
2. There is a circulation system—water is circulated through the motor to keep it cool.
3. There is the nervous system — ignition system — which discharges the electric spark that explodes the gas.
4. There is a lubrication system—the car must be regularly fed with oil or it cannot run.
5. The transmission system corresponds with the muscular system of the body. It is the means by which the energy of the machine is transformed into useful work.

In this book we have attempted to explain each of these systems and to show what sort of care is necessary to keep each one in perfect working order. Remember that an automobile is a wonderful piece of machinery. It is probably the most wonderful piece of machinery ever constructed, for no other machine involving so many parts and such careful adjustment is expected to stand the hard usage to which an automobile is subjected.

In taking care of your car, try to remember that each one of the five systems must be in perfect order for you to get the most satisfactory service. You would not neglect your body to the extent of failing to feed it, or doing anything to impair its circulation, its respiration, its nervous apparatus or its muscles. Try to give your automobile something of the same care and you will be amply repaid in faithful and uninterrupted service.



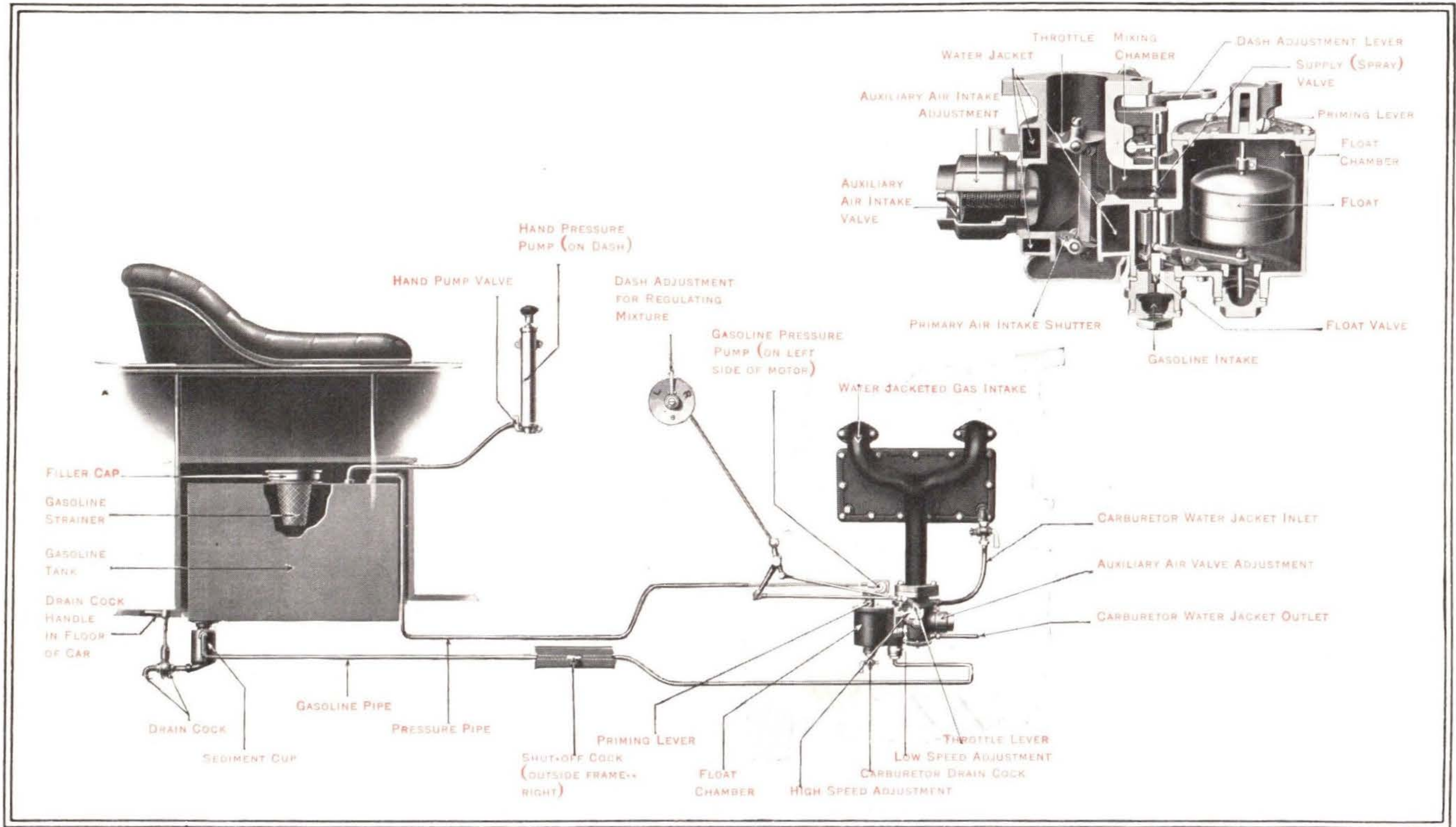

Fig. 6—Gasoline System of the Chalmers "Thirty-six"



# Gasoline System

## General Principles

The gasoline system consists of (1) the gasoline tank with sediment cup at bottom, and pressure regulator, (2) the gasoline pipe, (3) the carburetor and (4) the intake manifold. (See Fig. 6.) Liquid gasoline flows from the tank through the gasoline pipe to the carburetor. Here it is vaporized and mixed with air. The mixture is drawn by the suction of the descending piston into the cylinder where it is exploded by the spark.

## Gasoline Tank

The gasoline tank is located under the front seat. Capacity—touring car, 19 gallons; torpedo, 15 gallons, and roadster, 35 gallons.

In filling the gasoline tank always strain the gasoline through chamois skin to free it from water and impurities.

After filling be sure filler cap is tight.

## Pressure System on all "Thirty-six" Types

The flow of gasoline from the tank to the carburetor is insured by pressure in the gasoline tank.

## Pressure—How Secured

When the motor is not running, by means of a small hand pump located on the outside of the driver's seat, on the right side of the car.

When the motor is running, by means of a gasoline pressure pump, operated from the cam shaft. (See Fig. 7, Page 26.)

(See Figure 6 for general diagram of gasoline system.)

## Use of Pressure System

After the car has been standing for a considerable length of time or when it has been left standing on a grade with the front wheels higher than the rear wheels, pressure should be secured by use of the hand pump (See Fig. 6) before attempting to start the motor.

## Hand Pump Pressure Valve

At the lower end of the hand air pump is a three-way valve. When the handle of this valve is in a vertical position pointing upward, atmospheric pressure is admitted to the gasoline tank. Gasoline is then fed to the motor by gravity.

When the valve handle is in this position the pressure system is not in use. With a proper gasoline supply in the gasoline tank, located



under the driver's seat (See Fig. 6), the pressure system will not be required for driving over level roads where the motor obtains sufficient gasoline for gravity feeding.

Turning the handle of the hand pump pressure valve to a horizontal position permits the use of the hand pump for securing pressure.

After car has been standing, turn valve handle to this position and give pump six or eight strokes. This puts a sufficient amount of pressure into the gasoline tank to give a steady flow into the carburetor.

After securing pressure by the hand pump turn valve handle downward. Start motor in usual way.

When pressure is required quickly in any circumstances, hand pressure pump valve handle should be horizontal position. Hand pressure pump will not work with any other valve position.

Turning valve handle downward closes the air vent and allows pressure pump to form a pressure in the gasoline tank.

After using hand pump to secure first pressure, turning valve handle downward brings the pressure pump into operation. With hand pump valve handle downward in position, pressure pump will keep two pounds pressure in gasoline tank at all times.

This is the proper position for driving in hilly countries or when fuel supply is low in gasoline tank.

## Pressure Pump

(See Figure 7, Page 26, for sectional diagram.)

The pressure pump is attached to the forward end of the crank case on the left side. It is a simple two-cycle plunger pump and is operated by an eccentric on the cam shaft. As the cam shaft revolves a spring (A, Fig. 7) forces down a plunger (B). This creates a vacuum in the pump, which is filled by air rushing in through a port. Continued revolution of the cam shaft drives the air out of the pump through two other ports, and so into the gasoline tank.

This pump is so constructed that it will force only two pounds pressure of air into the gasoline tank, thus insuring sufficient pressure to give an even supply of fuel, but never enough pressure to place an undue strain on the gasoline tank.

## Care of Pressure System

The air pressure pump is lubricated from the crank case. No adjustments are necessary.

Should there arise a necessity for removing the pressure pump, simply remove four bolts in base. Pump is very simple to disassemble and reassemble.



Successful use of the pressure system depends largely upon keeping all joints and fittings tight.

Be sure the gasoline tank filler cap (See Fig. 6) is always air tight.

Leaks in the pressure system are indicated by the gauge on the dash. Pressure should show two pounds on the gauge in normal conditions. Lubricate hand pressure pump about once a month with four or five drops of thin oil. Oil hole will be found at top of pump. (See Fig. 6.)

## Sediment Cup

Beneath gasoline tank is placed the sediment strainer and cup from which the gasoline pipe leads to the carburetor. (See Fig. 6.)

The drain cock should be opened about once a week for withdrawing any water which has settled in the sediment cup. Allow a small quantity of gasoline to run out. Drain cock may also be used for draining off the gasoline.

Handle of drain cock will be found in the tonneau floor board, just back of the front seats.

Occasionally remove sediment cup and take out gasoline strainer for cleaning.

## Shut-off Cock

At the right side of the car near the dash is a cock by which the gasoline can be shut off from the carburetor if necessary. The handle of this cock projects through the frame and is readily accessible.

In the running position the handle of the cock is turned lengthwise of the frame. When the gasoline is shut off, handle of cock should be at right angles to frame.

## Carburetor

The carburetor is a device for producing a mixture of gasoline vapor and air in the correct proportion for complete combustion.

The carburetor consists of:

- 1—The float chamber which regulates the flow of gasoline so as to have a regular and constant supply for all motor speeds.
- 2—The mixing chamber in which the gasoline vapor is mixed with air in the proper proportion.



## Carburetor Float Chamber

The float chamber (See Fig. 6) maintains a constant level or supply of gasoline for the motor.

Gasoline flows from the feed pipe through a screen in the gasoline intake plug, thence through the float valve and into the float chamber. A hollow copper float fastened to a short lever raises or lowers the float valve, thus regulating the incoming flow of gasoline in proportion to the supply in the float chamber.

## Carburetor Mixing Chamber

After leaving the float chamber the gasoline passes through a nozzle (See Fig. 6) from which it is sprayed in a fine stream into the mixing chamber. The quantity of gasoline passing through the nozzle is regulated by the "supply valve." The supply valve of the Rayfield carburetor is adjustable both from the dash and by the throttle. The dash adjustment of the carburetor (See Page 11) gives a "light" or "rich" mixture by simply turning a thumb lever to the right or left. This makes the carburetor adjustable for all conditions of weather and altitudes. In addition to this dash adjustment the supply valve opens as the throttle is opened. This is a purely automatic operation and maintains the proper mixture for all motor speeds.

## Action of the Carburetor

The action of the carburetor is as follows:

The suction created by downward motion of the motor pistons draws air into the mixing chamber through both the primary and auxiliary air inlets. (See Fig. 6.) This air floats into the mixing chamber around the nozzle and picks up the gasoline which leaves the nozzle in the form of a spray. Thus the action of the mixing chamber is not unlike that of an ordinary atomizer in which the air forced from the rubber bulb picks up a certain amount of the liquid in the bottle and sprays it out in the form of a fine vapor.

That the proportion of air and gasoline in the mixture may be correct for all motor speeds, two air inlets are provided. The lower one, or the "primary air inlet" opens and closes with the throttle, giving a greater volume of air in proportion to the greater amount of gasoline to be vaporized. In other words, at high motor speeds or when the throttle is fully open, the motor requires more gas and consequently a greater volume of air to vaporize the gasoline which comes through the supply valve; at low motor speeds less gas is required and consequently less air is necessary to vaporize the gasoline.

At the front end of the carburetor is the "auxiliary" air inlet. This is controlled by a spring. (See Fig. 6.) At low speeds when only a small amount of air is being drawn through the carburetor the spring holds this valve almost shut. As the speed increases and more air is needed the suction operating against the tension of the spring draws the valve further and further open, thus giving an increased supply of air exactly in proportion to the need for the increased speed. The carburetor thus automatically produces the correct mixture for all motor speeds.



The auxiliary air valve of the Chalmers "Thirty-six" carburetor is readily adjustable. By turning the valve casing toward the motor the auxiliary inlet valve spring is tightened, requiring a greater suction by the motor to open the valve; by turning the valve casing toward the operator, tension on the valve spring is lessened, making the auxiliary air inlet valve more susceptible to the suction of the motor.

### Do not unnecessarily adjust the carburetor.

While the carburetor of the Chalmers "Thirty-six" is especially easy to adjust, the operator should not make adjustments that are not absolutely required. Once the carburetor has been satisfactorily adjusted there is little chance of its getting out of adjustment. In ordinary circumstances only an extreme change in weather conditions will make adjustments necessary.

Look elsewhere for trouble.

### Adjustments:

If the weather is cold or extremely humid turn the dash adjustment of the gasoline supply valve to the right while the motor is running, until it fires evenly under load, or while the car is in motion. Too rich a mixture will be distinguishable by black smoke from the exhaust. Too light a mixture will cause uneven firing of the motor.

If the weather is hot or extremely dry, move the dash supply valve adjustment lever to the left, being careful not to make the mixture so light that the motor will not fire evenly.

If, following the adjustment of the gasoline supply valve, the mixture is not such as to give the best results, it may be found necessary to adjust the auxiliary air valve for more or less air; turning away from the operator and toward the motor for less air, and toward the operator and away from the motor for more air.

Unless absolutely necessary do not adjust the auxiliary air valve.

On the throttle lever and at the base of the dash supply valve adjustment lever (See Fig. 6) are two nickel plated screws for the permanent adjustment of the gasoline supply valve. Do not touch these except under the direction of a Chalmers dealer.

If difficulty is found in securing the proper mixture for the carburetor, consult a Chalmers dealer.

### Priming the Carburetor.

As explained above, when the gasoline rises to a certain height in the float chamber, the float valve automatically closes. If, for any reason, it should be desirable to have a greater pressure of gasoline in the carburetor (as, for instance, in extremely cold weather), pull the priming lever at the top of the float chamber. (See Fig. 6.) This lever pushes down the float and opens the float valve, admitting additional gasoline.

## Throttle Valve

The throttle valve, which is of the "butterfly" or "shutter" type, is located just below the inlet manifold. (See Fig. 6.) It is connected by a rod, with the hand throttle and the foot accelerator (See Page 11).

## Hand Throttle

The longer of the two levers at the top of the steering wheel controls the throttle.

Moving this lever upward around the quadrant increases the speed of the motor and moving it down decreases the speed.



## Foot Throttle or Accelerator

In the floor to the right of the clutch pedal is a small brass foot throttle or accelerator which is operated by the right foot.

By pressing down upon the foot throttle the same control over the speed of the car can be obtained as by manipulation of the hand throttle lever.

## Use of Hand Throttle and Accelerator

The accelerator pedal or foot throttle is the usual means of controlling the speed of the car.

Pressing it down for increased speed or releasing it for decreased speed gives instantaneous action.

When the accelerator is released the motor immediately resumes the speed determined by the position of the hand throttle on the steering wheel quadrant.

Although either hand throttle or accelerator pedal may be used to control the speed of the car, beginners are advised to confine themselves to the use of the hand lever. After the operator has gained confidence in his ability, the more quick-acting foot throttle will be preferred.

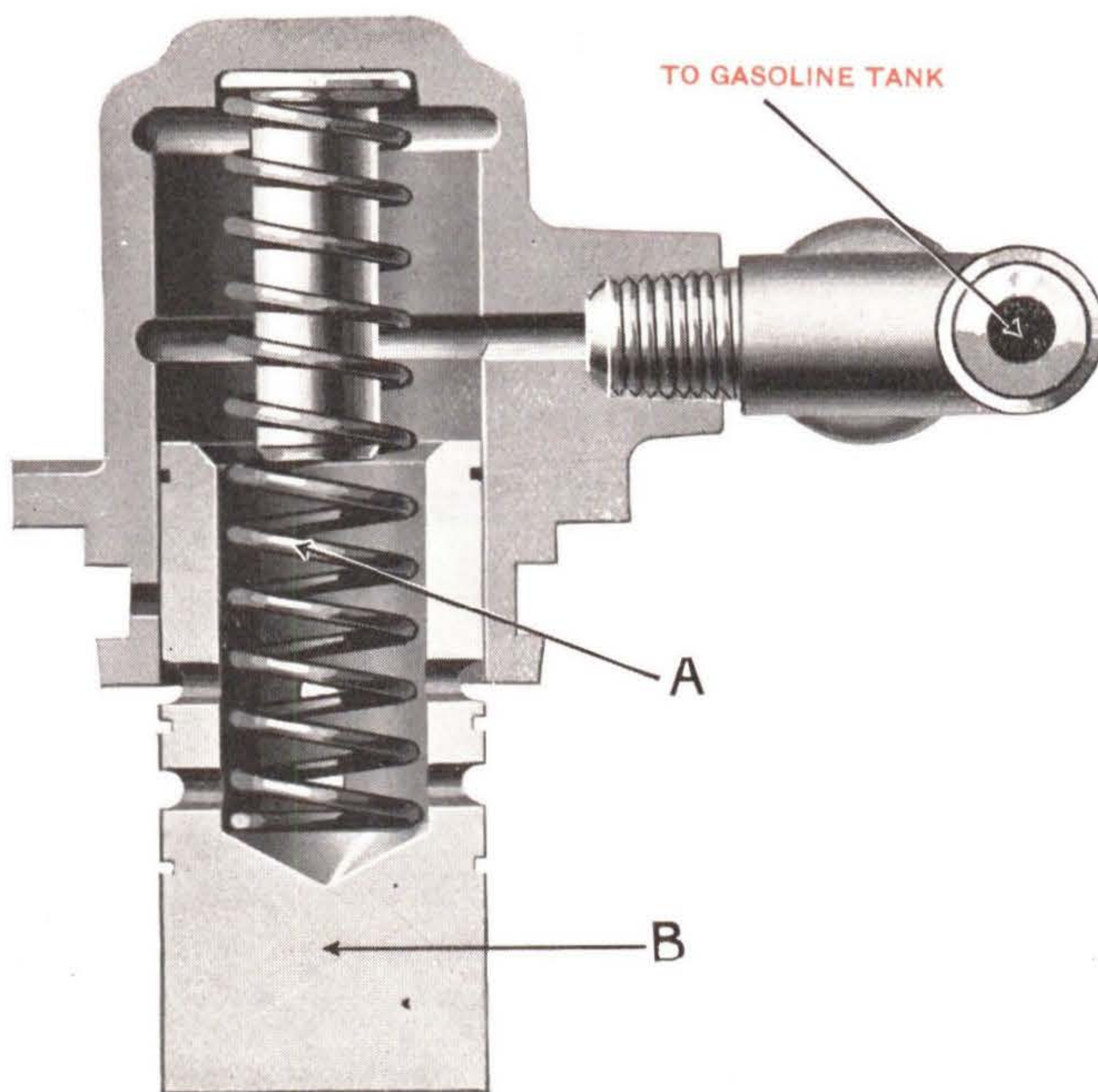

Fig. 7—Gasoline Pressure Pump.



# Ignition System

## General Principles

The purpose of the ignition system is to furnish an electric spark in each of the four cylinders in their order of firing, the spark being so timed as to explode the compressed charge of gas in the combustion chamber at just the right instant. The electric current may be furnished by a battery or a magneto. In the case of the Chalmers "Thirty-six," what is known as the "dual ignition" system is used. This system provides a magneto which serves as the source of a spark in regular running, a storage battery which generates the spark in starting the car, a transformer coil, a dash kick switch and a single set of four spark plugs.

For starting and for reserve, there is the storage battery. This furnishes a low tension current which is transformed into a high tension current by the coil located just under the cowl of the dash.

## The Battery

The voltage of the storage battery is 6 and it has a capacity of 40 ampere-hours. The charging rate is 5 amperes.

The battery is in a water-tight metal box contained in the tool box on the left running board. From the battery (Fig. 8, page 28) the wires run forward inside the left frame to the coil fastened to the sub-frame.

The battery should be re-charged whenever its voltage drops to 5.40.

It is advisable to test the battery with a volt meter twice a month. To secure maximum efficiency the storage battery should be discharged and recharged at least once in six weeks.

Ordinarily it is wisest to have the battery charged and cared for by a Chalmers dealer or by someone else thoroughly familiar with such work. If, however, you wish to attend to the charging and other care of the battery yourself, complete instructions will be furnished upon request, by the Service Division of the Chalmers Motor Company.

After charging, wash the top of the battery with water to remove traces of acid. Be careful not to get any of the solution upon the clothing.

The metal terminals by which the battery wires are attached to the battery should always be kept clean and tight.

## The Battery Coil

The object of the coil located behind the extended cowl of the dash, is to convert the low tension current into a high tension current strong enough to make a hot ignition spark.

(Each time the primary circuit is made and broken, a stronger high tension current is induced in the secondary coil.) From here a high tension current flows through the wire (Fig. 8) to the distributor block on the magneto, whence it is distributed through the wires to



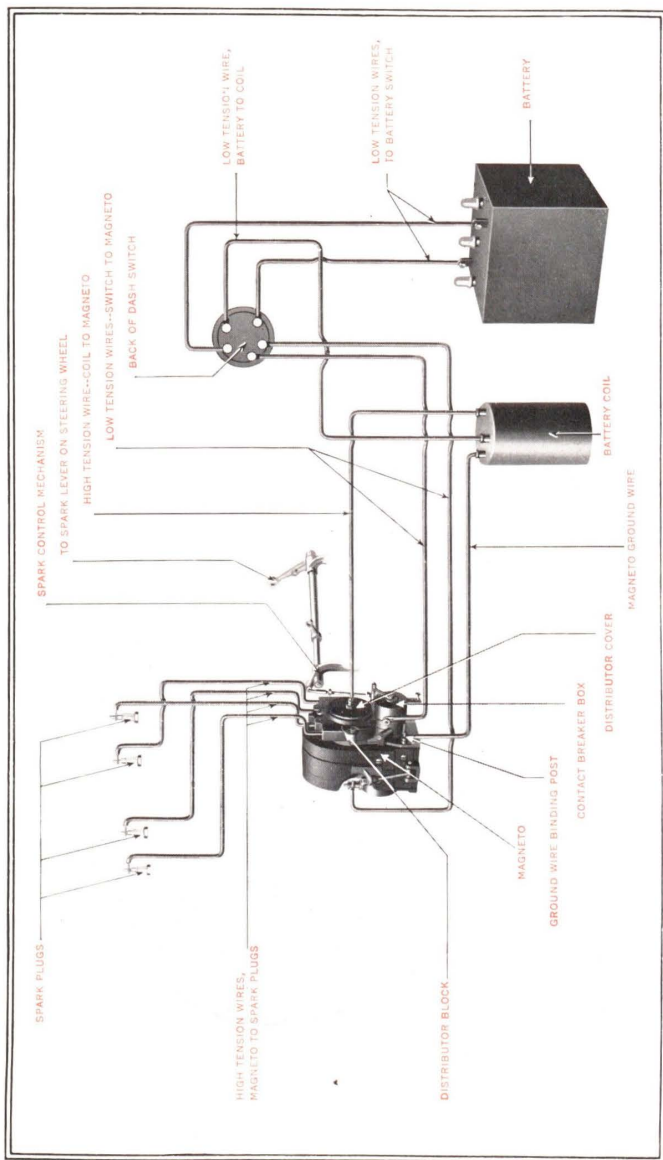

Fig. 8—Ignition System of Chalmers "Thirty-six"



one of the four spark plugs. The final result is a brief arc of flame in the motor cylinders, causing the explosion of the compressed gas in the combustion chamber.

## Magneto

The magneto is on the left side of the motor toward the rear (Fig. 8). It is bolted to a platform especially designed to carry it and is driven by the same shaft that operates the water pump. The magneto is, in effect, a small dynamo. By its magnets and armature it develops through the coil a high tension current when the motor is running.

## Action of Magneto Current

A low tension current is produced in the armature winding by the rotation of the armature. A high tension current is induced in the secondary winding of the coil by the interruption of the primary circuit. This interruption is secured by means of a "contact breaker" at the end of the armature.

The distributor on the rear end of the magneto sends the high tension current through the spark plugs of the respective cylinders in succession, firing them in the order, 1, 3, 4, 2.

## Care of Magneto

The magneto furnished for Chalmers cars requires very little attention. It should never be tampered with unless you are sure something is wrong. For lubrication see Page 14.

The circuit breaker mechanism on the armature shaft should always be kept clean and with the contact points flat, parallel and accurately adjusted. If the platinum contacts after much usage become pitted so that a bad contact results, they can be filed flat with a fine file, taking care not to file off any more than is necessary. Then reset the screw so that the break is no more than a thick piece of tin or about 1-32 of an inch. The distributor should be kept clean and needs no oiling.

## Setting the Magneto

To replace the magneto after removal, proceed as follows:

Crank the motor until the piston in No. 1 cylinder has reached the end of the compression stroke or its uppermost position.

(The compression stroke may be determined by holding the finger on top of the No. 1 cylinder relief cock.)

The motor is then in the proper position to fire.

The distributor block should then be removed from the magneto. This is done by taking out two screws at the side and one at the top of the distributor block. The distributor mechanism will then be revealed.

Next revolve the armature until the distributor segment comes in contact with the left-hand lead, looking toward the distributor block from the back of the magneto. This is the wire which carries the current to No. 1 cylinder. (See Fig. 8).

The armature should then be retarded slightly until the breaker points just begin to open with the breaker box in full retard.



Set the magneto in place and connect the couplings. Connect the spark control rod. Adjust this rod and its connections so that the contact points in the "contact breaker box" just start to open when the spark lever on the steering wheel is fully retarded, with the motor on "dead center." When the motor is on "dead center," the breaker box should always be in full retard with the spark lever at the bottom of the quadrant. This is to give the maximum amount of advance on the magneto. If the make and break does not occur at the proper time, go over the above directions again.

## Magneto Connections

The wiring connections of the magneto are shown in Fig. 8.

After setting the magneto the high tension wire should be connected up as follows:

No. 1 post (counting the posts on the back of the magneto from left to right) is connected to No. 1 cylinder.

No. 2 post is connected to No. 3 cylinder.

No. 3 post is connected to No. 4 cylinder.

No. 4 post is connected to No. 2 cylinder.

The "magneto-to-switch" wire goes from the binding post on the "contact breaker" to the post on the back of the dash kick switch. (Fig. 8.)

## Timing the Spark

The time at which the spark occurs in the cylinders relative to the travel of the piston is controlled by the contact breaker at the rear end of the magneto armature.

Although combustion of the gasoline vapor under compression in any cylinder occurs rapidly, it is not absolutely instantaneous. There is a certain point in the travel of the piston relative to the motor speed at which the occurrence of the spark will give the maximum efficiency.

Ordinarily the spark occurs and the combustion of the gasoline vapor begins just before the piston reaches the highest point of its stroke. If, however, the spark is too far advanced for any given motor speed the maximum effect of the combustion is exerted so long before the piston reaches its highest point that there is a tendency for the motor to run backward.

If the motor is running fast enough this tendency is overcome by the momentum of the flywheel. If, on account of low speed, the momentum of the flywheel is not sufficient, there will be a tendency for the car to run with a jerky motion and the motor may be "stalled." This premature ignition is likely to occur if the engine is cranked with the switch on "battery" and the spark lever in a too far advanced position. In such case the starting crank will "kick" backward with possible injury to the operator.

**IMPORTANT**—Never crank the engine unless the spark lever is fully retarded.

If the spark is too far retarded for the speed of the motor the maximum effect of the combustion is exerted so long after the piston has passed its highest point that some of the energy is wasted, and not being converted into mechanical work, remains in the cylinder as heat, tending to over-heat the motor. The regulation of the spark is by means of the spark lever (the shorter lever at top of steering wheel), as explained on Page 7.

In ordinary driving, carry the spark lever as far advanced as possible without causing the motor to knock.



## Spark Plugs

The gap between the points of the spark plugs should be about 1-32 of an inch or approximately the thickness of a dime.

Too wide or too narrow a gap will impair the efficiency of the motor, and misfiring will result.

The adjustment given above gives a good spark for slow running and hard pulling as well as for high speed driving. Spark plugs should be kept clean to prevent short circuiting.



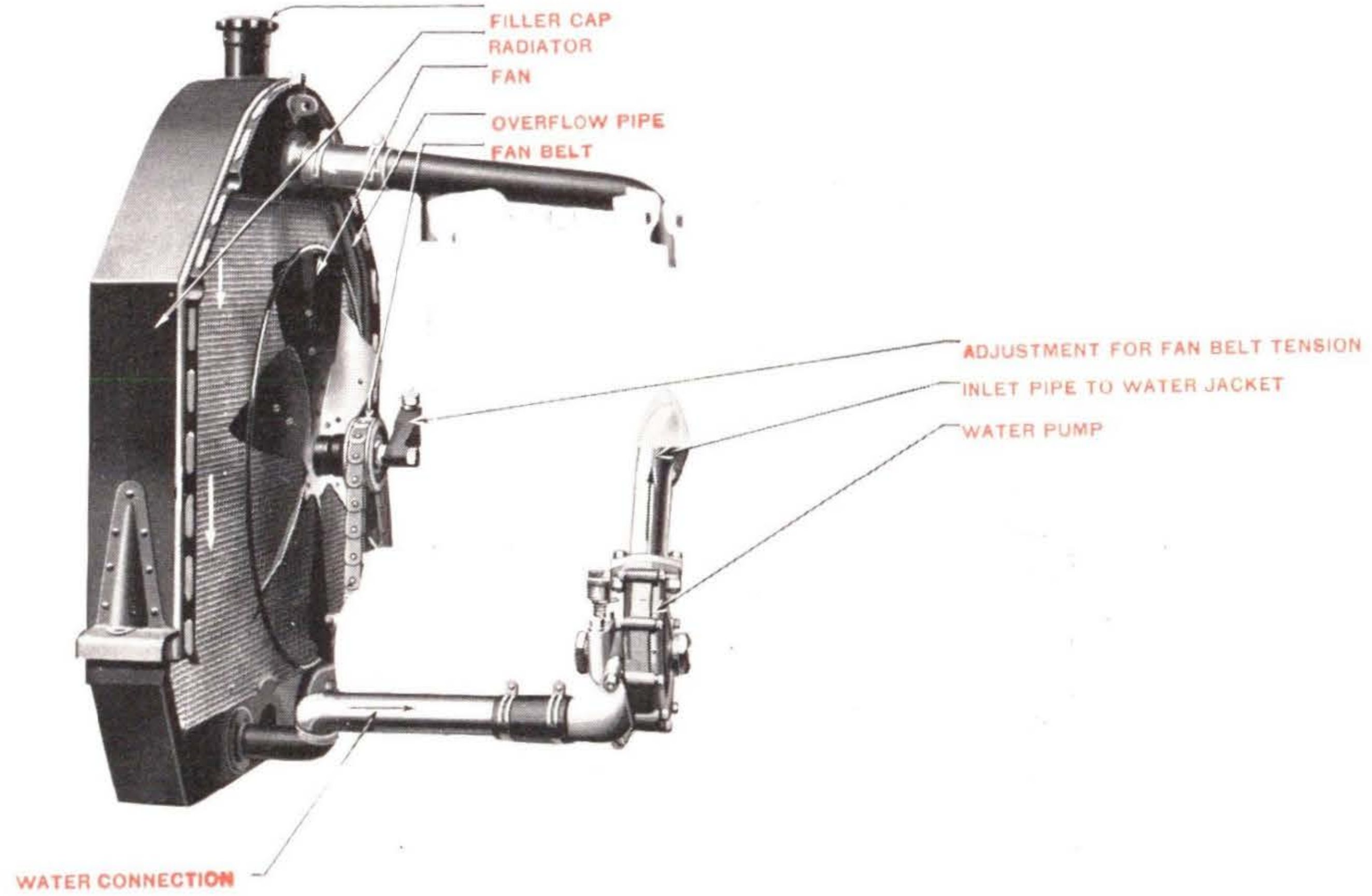

Fig. 9—Water Circulation System of Chalmers "Thirty-six"



# Water Circulation System

## General Principles

The repeated explosions of gasoline vapor in the cylinders of the motor develop a great deal of heat. It is necessary to cool the cylinders by circulating water around them through the "water jacket." The water, of course, soon becomes hot, and, in turn, is cooled by passing through the radiator. The radiator is composed of a large number of cells which expose to the air a large surface which permits of the rapid radiation of heat. From the lower compartment of the radiator the cool water is returned to the water jackets of the cylinders by a water pump, thus keeping up a constant circulation. (Fig. 9.)

## Filling the Radiator

Keep the radiator filled with clean water, as free as possible from lime or other impurities.

In filling the radiator, always pour the water through the screen provided. Never pour cold water into an empty or nearly empty water system when the motor is excessively hot as the result of having run it dry.

Occasionally when filling, drain the dirty water out of the water system through the drain plug at the bottom of the radiator.

Steam or surplus water can escape from the top of the radiator through an overflow pipe which extends from beneath the filler cap down to the lower right corner of the radiator. (See Fig. 9.)

## Water Pump

The water pump—centrifugal type—is attached to the left side of the crank case and is directly driven by means of gears in the gear case at the front of the motor (Fig. 20, Page 54).

It draws water from the bottom compartment of the radiator, forces it up through the inlet connections into the water jackets of the cylinders. After circulating around the cylinders and becoming heated, the water is forced through the outlet pipe on top of the cylinders to the top compartment of the radiator.

## Fan

The fan draws a current of air through the radiator, thus insuring more rapid cooling.

The fan is supported on an arm fastened to a stud on the front of the cylinder casting. The tension of the fan belt is regulated by adjusting this arm on the stud. The belt should be kept tight at all times. Care should also be taken to see that the clamp which fastens the supporting arm is tight.

## Cleaning the Water System

The radiator, cylinder jackets and other parts of the water system should be cleaned occasionally.

To clean the radiator, uncouple the hose connections and flush out by forcing water through it under city pressure from the bottom to the top. Flush the cylinder jackets in a similar manner, letting the water flow in at the top and out through the water pump.

Flush water jacket of carburetor. This need not be done frequently, but the careful owner will see to it that the water system is cleaned whenever the car is overhauled.



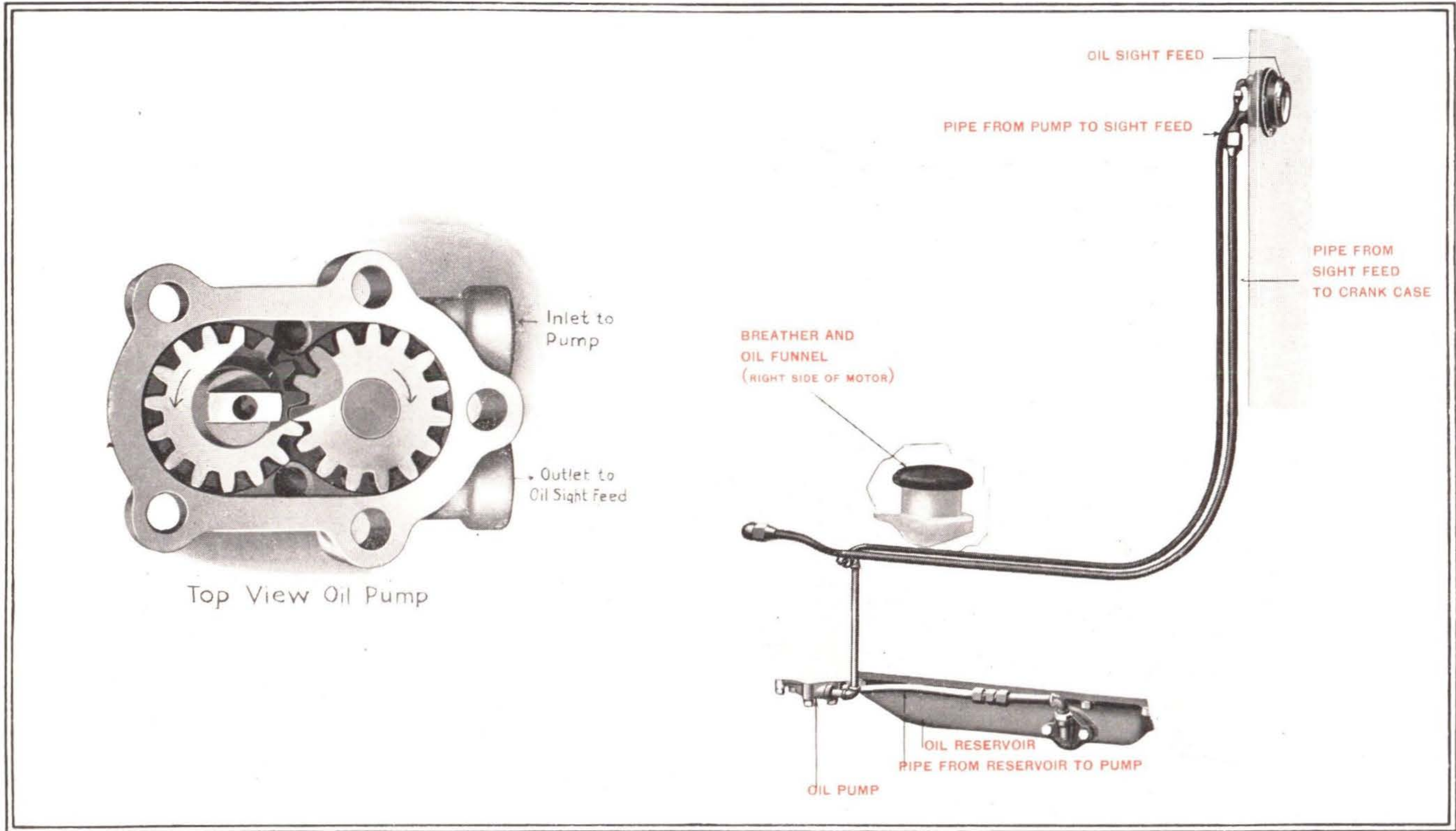

Fig. 10—Motor Lubrication System of the Chalmers "Thirty-six"



# Lubrication System

## General Principles

The Chalmers "Thirty-six" motor is lubricated by what is known as the constant level splash system. The bottom of the crank case contains oil into which, as the crank shaft revolves, the ends of the connecting rods dip, splashing oil all over the interior of the motor and lubricating every part. Splashing also lubricates main crank-shaft bearings and timing gears.

The level of oil in crank case is regulated by overflow holes which open into the reservoir below (Fig. 10 and Fig. 11).

From this reservoir fresh oil is continually supplied to the crank case by a gear pump. In passing from the pump to the crank case the oil goes through the "sight feed" on the dash, thus enabling the driver to note at all times whether or not the oil is flowing properly.

The transmission gears and clutch run in oil contained in their respective casings (See Pages 13 and 14).

Universal joints are packed in grease (See Page 14).

Differential driving gears are packed in grease and oil (See Page 14).

All other working parts are lubricated by means of grease cups, oil cups or oil holes.

## Importance of Lubrication

Proper lubrication of a motor car is more important than any other one item in its care.

Full instructions telling how often to oil the different parts and what kinds of lubricants to use, are given under "Directions for Lubrication," Page 13.

## Lubricants

It pays in the long run to use the best quality of lubricants. Money saved by buying cheap oils or grease will be lost in worn out bearings or cylinders.

There are many good oils on the market. Our own experience has shown that the following are well suited for use on Chalmers cars:

Chalmers Cylinder Oil	Havoline	Mobile "A"
Monogram "V"	Floyd's Anti-Carbon	Polarine
Mobiloil Arctic	Standard Light Auto	

For grease cups use a good grade of cup grease of medium consistency.

## Oil Reservoir

The height of oil in the reservoir (Fig. 21, Page 56) is determined by two try cocks on the right hand side. Oil should be poured into the crank case through the "breather pipe" or funnel (Fig. 10 and Fig. 21) until it just begins to flow out of the top try cock. The level must never be allowed to drop below the lower try cock.

The oil reservoir may be removed from below when it is necessary to get at the inside of the crank case (Fig. 21, Page 56). Be sure to drain out the oil before removing the reservoir (See Page 37).

capacity of oil reservoir four to five quarts.



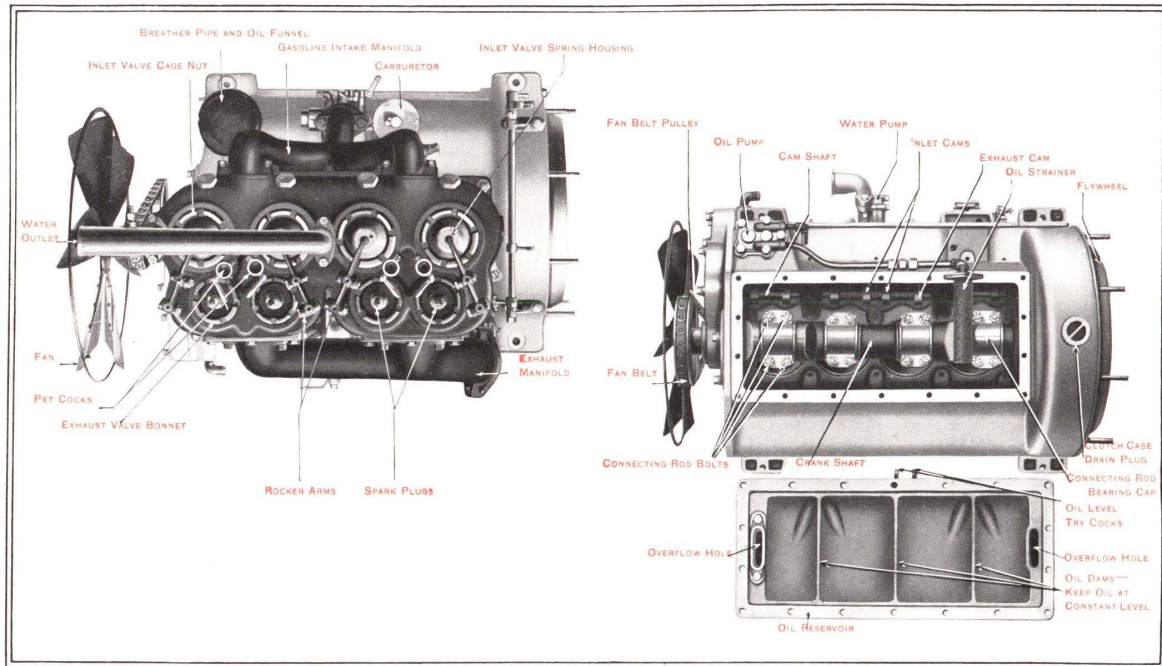

Fig. 11—Top and Bottom Views of Chalmers "Thirty-six" Motor



## Oil Pump

The oil pump is located at the front end of the crank case on the left side and is of the gear type.

The oil pump consists of two simple gears, the spaces between the teeth of which act as cups to force the oil from the reservoir through the pump to the sight feed.

The oil pump is driven by spiral gears on the magneto shaft.

Ordinarily this pump will require no attention. It is easily removed, however, for cleaning, which should be done once each season.

## Oil Sight Feed

The sight feed on the dash is of the bull's-eye type with an oil chamber  $2\frac{5}{16}$  inches in diameter. The interior of the oil chamber is white enameled.

So long as the pump is throwing oil properly the oil chamber of the sight feed will be filled with oil to a depth of about half an inch, and oil will flow down the perpendicular wire in the oil chamber in a steady stream. If oil stops flowing or the oil compartment of the sight feed becomes empty, inspect the oil system at once as the motor should not be run at all if the oiling system is not working properly.

## Increased Lubrication for Fast Running or Touring

Fast running or touring over heavy and hilly roads uses up oil much faster than city use. The wise motorist, remembering this, will add oil frequently on a tour or for fast driving.

It is not much trouble to put in an extra pint of oil every hundred miles or so. This precaution will avoid chances of trouble with worn bearings or cylinders.

Roadster has reserve oil tank holding 7 gallons.

## Draining Off Old Oil

Every thousand miles the old oil in the crank case should be drained off and a fresh supply poured in.

The old oil may be drained off by removing the drain plug at the rear end of the oil reservoir (See Fig. 21).

The oil screen which is attached to the reservoir oil pipe (See Fig. 11) should be removed and thoroughly cleaned every one thousand miles. If the oil drawn off is very dirty or heavy it is a good plan to remove the oil reservoir and clean thoroughly with kerosene. Replace oil reservoir and fill with new oil through breather pipe, to the level of the top try cock.

## Insufficient Lubrication

If, through oversight, the motor has been allowed to run without sufficient lubrication and begins to heat or pound, it should be stopped immediately.

Allow the motor to cool. Fill up reservoir to top try cock and then add a pint or two extra. Fill the radiator with water after the motor is thoroughly cooled.

If there is any apparent damage, the motor should be thoroughly inspected before driving. If no apparent damage has been done, the motor should be given a thorough examination at the earliest opportunity to see that no harm has resulted to the bearings.



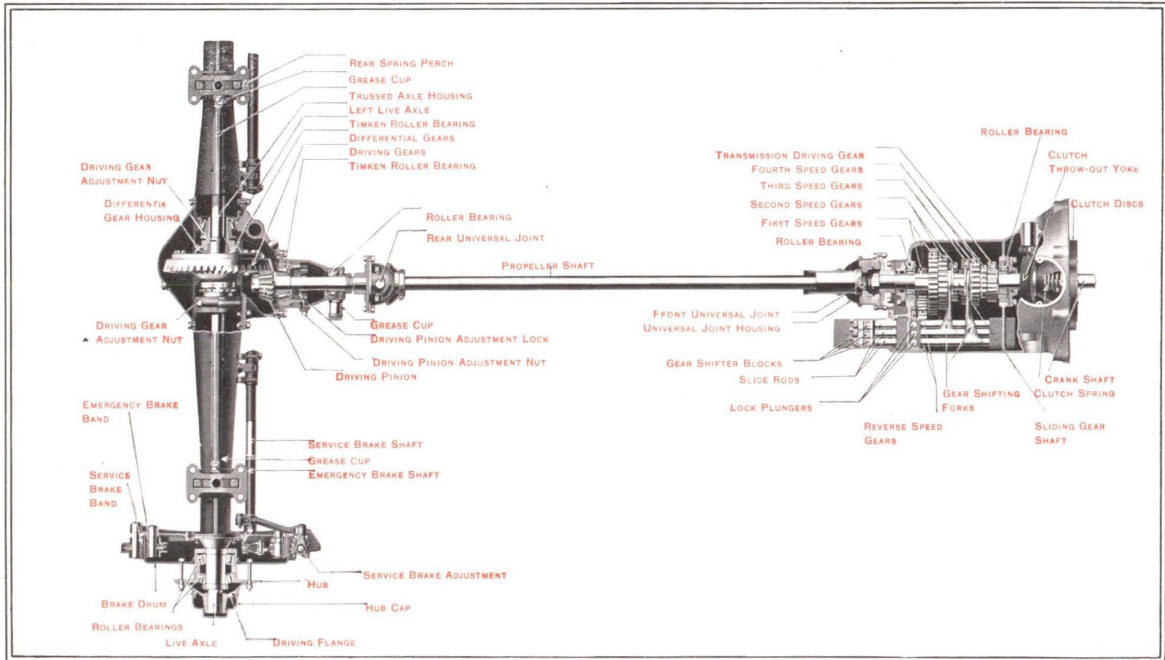

Fig. 12—Power Transmission System of Chalmers "Thirty-six"



# Power Transmission System

## General Principles

The transmission system by which power is transmitted from the motor to the rear wheels consists of (1) Clutch; (2) Transmission; (3) Front Universal Joint; (4) Propeller Shaft; (5) Rear Universal Joint; (6) Differential Driving Gears; (7) Live Axle Shafts which turn the rear wheels.

## Clutch

The Chalmers "Thirty-six" Clutch is of the multiple disc type, running in a bath of oil. (For oiling directions, see page 13.)

The clutch consists of 39 alternating tempered saw steel discs (Fig. 13, Page 40), 20 of which are connected with three pins on the flywheel (Fig. 20, Page 54) and 19 of which are keyed on the main driving shaft of the transmission. When the clutch is thrown out these discs are allowed to separate, the 20 plates rotating with the flywheel and 19 plates remaining still on the transmission shaft. When the clutch is "let in," the clutch springs (Fig. 13, Page 40) force both sets of discs together and the whole combination rotates. The clutch is disengaged by pressing on the foot pedal.

## Care of the Clutch

The clutch case should contain 1 quart to 3 pints, one-half motor oil and one-half kerosene.

If the clutch slips or drags, drain out the old oil through the hole at the bottom of the case (Figs. 20 and 21), replace the plug and pour in a quart of kerosene, starting the motor and running the car for a few minutes, working the clutch in and out to cut old oil off the plates. Then drain out dirty kerosene and fill case as instructed above.

If the slipping of the clutch cannot be remedied by the above cleaning, the clutch springs may be tightened. Adjust clutch springs through "hand hole" on slanting portion of case. (Fig. 13.) Care should be taken to tighten springs equally.

## Transmission

The purpose of the transmission (Fig. 13) is to increase the power of the motor for pulling the car through heavy going or up hills—also to provide a mechanism for reversing the direction of the car's motion.

The Chalmers "Thirty-six" transmission is of the selective sliding gear type. This means that the gears slide back and forth on a shaft and that the operator, starting from neutral, can set his gears at any speed he selects, without passing through intermediate speeds.

## The Action of Speed Changing Gears

The four forward speeds are obtained by the movements of two gears sliding upon the "sliding gear shaft" (See Fig. 13) and keyed to it.



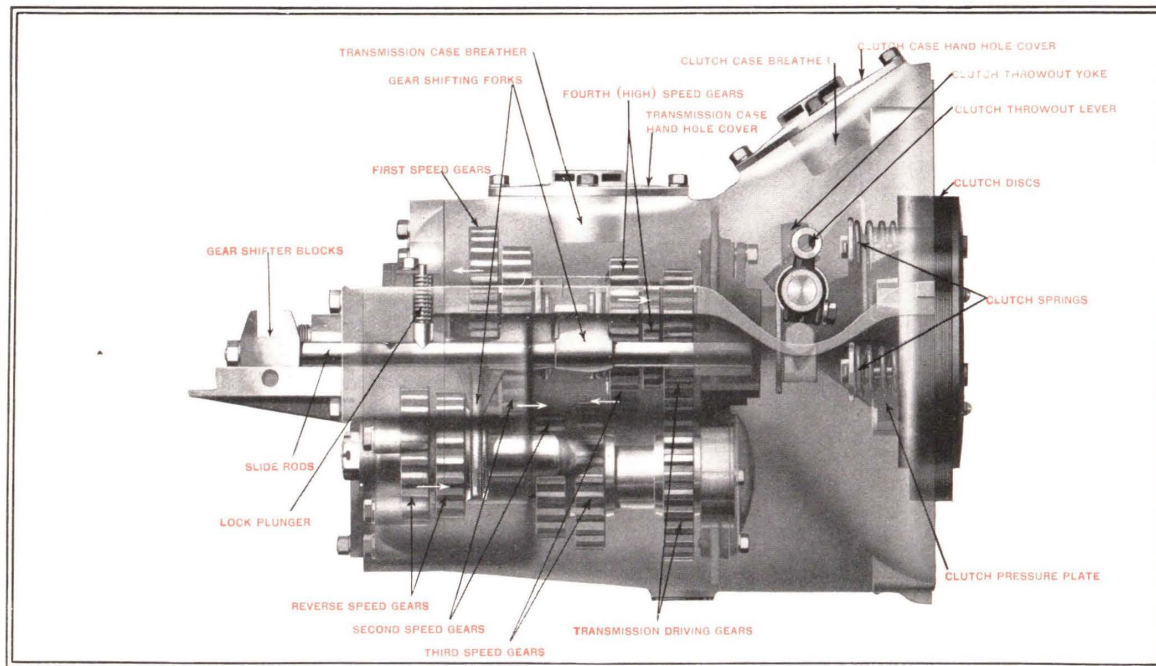

Fig. 13—Four Speed Transmission and Multiple Disc Clutch of the Chalmers "Thirty-six"



These gears are moved back and forth by the "gear shifting forks" (See Fig. 13) fastened to the "slide rods" (Fig. 12) which are in turn moved by the gear shifting lever which slides back and forth in the "gear shifter blocks" (Fig. 13).

Sliding the "first speed gear" (Fig. 13) backward, engages it with a gear on the lower transmission shaft and moves the car forward on first speed.

Sliding the "second speed gear" forward (Fig. 13) on the clutch shaft, engages it with a gear on the lower transmission shaft and drives the car forward on second speed.

Sliding the "third speed gear" (Fig. 13) backward on the clutch shaft engages it with a gear on the lower transmission shaft and drives the car forward at third speed.

Sliding the "fourth speed gear" (Fig. 13) forward on the clutch shaft, interlocks it with the "transmission driving gears" (Fig. 13) and drives the car forward on fourth or high speed.

Sliding the "fourth speed gear" (Fig. 13) forward on the shaft, interlocks it with the "transmission driving gears" (Fig. 13) and drives the car forward on fourth or high speed.

The reverse speed is obtained by sliding forward the "reverse speed gears" (Fig. 13) so that they mesh with gears on the lower transmission shaft.

### Movements of Gear Shifting Lever

The four forward speeds and reverse are obtained by movement of one change speed, or gear shifting hand lever. The method of making gear changes is described under "General Directions" (Pages 9 and 10). The lever moves in two directions, forward and back, in and out. The five positions of the lever to obtain the various speeds are shown in figure 14.

The gear shifting lever of the Chalmers "Thirty-six" moves in a quadrant of the "sliding gate" type.

In neutral position, with no gears engaged, the lever is in the middle of the quadrant (See Fig. 14).

The gear shift lever is provided with a spring catch which prevents the operator from throwing his gears into reverse accidentally. In changing gears to secure any of the four forward speeds, care should be taken not to press button at top of gear shift lever.

In first speed position, the lever is brought in toward the driver and pushed forward to the end of the quadrant slot.

In second speed position, the lever is brought in toward the driver and back to end of quadrant slot.

In third speed position, the lever is moved outward from the driver and forward to end of quadrant slot.

In fourth speed position, the lever is moved out from the driver and backward to end of quadrant slot.

In reverse position, the lever is moved in to slot nearest driver and pulled backward to end of slot. Be sure to push button at top of gear shift lever when shifting to reverse.

By these movements of the hand lever, three "slide rods" are moved backward and forward. Attached to these rods are the gear shift forks which move the gears (See Fig. 13).

### Speed Changing Procedure

Be sure always to disengage the clutch before attempting to shift gears.

Do not shift the gears forward too hurriedly, but do not delay so much after clutch has been disengaged that car slows down.

Experience will teach the proper speed to acquire on one gear before changing into the next higher gear. This speed will depend upon road conditions and the load.



When changing from a higher to a lower speed, shift gears quickly; do not allow the speed of the motor to decrease.

There should be little or no noise in making gear shifts. If there is a clash or clatter of gears, it means that the operation is poorly done. Unskillful gear shifting is hard on the transmission.

Be sure always to leave the gear shift lever at neutral position when you stop the car.

### Adjustment of Gear Shifting Mechanism

There should be little occasion to disturb the adjustment of the gear shifting mechanism. Such adjustment should be made by a Chalmers dealer. In case an owner has to make the adjustment himself, the following directions are given:

Figure 13, page 40, shows the sliding parts of the transmission. A notch (Fig. 13) in each slide rod engages a "lock plunger" or wedge-shaped catch, which prevents the rod from working back and forth unless operated by the hand lever. When the gears are properly intermeshed the little wedges will enter the notches and prevent the gears from shifting. When gears are in neutral position, the "transmission gear shifter blocks" (Fig. 13) at the rear ends of the slide rods should be in line so that the hand lever slides freely from one slide rod to another. These blocks are held in position by a nut on the rear end of each slide rod.

### Adjustment of Differential Driving Gears

The function of the differential driving gears (Fig. 12) is to allow the two rear wheels to turn at different rates of speed, as in going around corners or on bumps.

This is accomplished by means of a series of small bevel gears inside the large "driving gear."

The differential gears should require no attention. If, however, anything should arise necessitating adjustment, be sure to have it done by a Chalmers Dealer. Incorrect adjustment of these gears will mean trouble and noise.

If it becomes necessary for an owner to make such an adjustment himself, he should communicate with the Service Division of the Chalmers Motor Company.

### Cleaning and Oiling Transmission and Differential

Complete directions for draining, cleaning and oiling transmission and differential gear cases are given in the directions for lubrication, beginning on page 13.



Fig. 14—Movements of Gear Shift Lever in Changing Speeds



# Compressed Air Starting System

## General Principles

The Chalmers "Thirty-six" compressed air starting device operates through the introduction of compressed air into the cylinders, which are ready for the working stroke, in their order of firing.

While the Chalmers Self-starter is simple and positive in its operation, it should be thoroughly understood by the operator. To comprehend the functions of the various parts of the Chalmers Self-starter, the operator should thoroughly familiarize himself with the principle of the four-cycle gasoline engine (See page 16).

It is obvious, that when the motor is standing still, it has to be given an impulse before the explosions in the cylinders occur. The simplest method of accomplishing this is by means of a starting crank by which the motor is turned over or "spun," allowing it to take up its various functions. A second, but less positive method, is starting on the spark. The Chalmers Self-starter supplants these methods operating the motor with compressed air until regular explosions take place in the cylinders. The air supply is then shut off and the motor takes up its regular operations.

The parts of the Chalmers Self-starter are as follows (See Fig. 15): a high pressure four-cylinder air pump for compressing air in "storage tank;" a pipe for carrying air from pump to storage tank; a pipe which carries air from storage tank to "push valve" on dash; a pipe which carries compressed air from the push valve to the "distributor;" four pipes through which air is carried from the distributor to the various cylinders; "poppet valves"—one in each of the four cylinders—by means of which compressed air from the distributor is admitted to the cylinder ready for the working stroke; a "pressure gauge" on the dash which keeps the operator informed of the amount of compressed air in the storage tank; a "pump clutch," operated by a foot pedal, which throws the gears of the air pump into mesh.

## Air Pump

The four-cylinder air pump is located at the left side of the motor toward the front. (See Fig. 15 and Fig. 17.) It is a simple device for compressing the air and delivers a steady flow of compressed air to the storage tank. The pump is driven by a silent drive chain from the water pump shaft, and operates only when the gears are thrown into mesh by pressing the pump clutch foot pedal.

Fifty pounds air pressure in the storage tank will start the motor under ordinary conditions, but it is advisable to keep the pressure at about 150 pounds.

The pump is lubricated by a constant level splash system similar to that of the motor. Enough of the oil in the pump crank case works up to the underside of piston leathers to keep them in perfect condition; yet the pump will not deliver oil, but pure air. The pump crank case will hold about 2 ozs. of oil, and should be filled with Heavy (600-W) Steam Cylinder oil at least once a week. To lubricate pump remove breather cap (Fig. 17) and pour in the required amount of oil. The



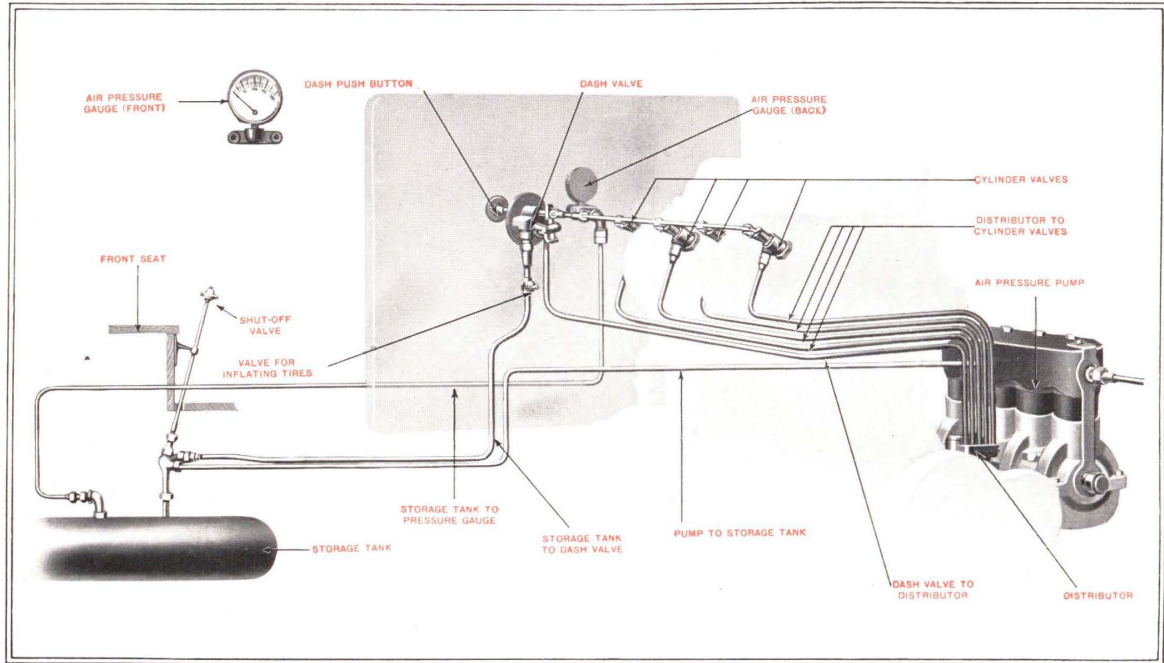

Fig. 15—Air Pressure Starting Mechanism of Chalmers "Thirty-six"



whole pump should be kept as free from dirt and grease as possible, especially the end bearings and the air intake ports at the base of the cylinders. If dirt passes through the air intake ports, it is liable to be drawn up into the check valve and lodge there so that the valve cannot seat. This will cause the pump to lose the use of that cylinder. If this happens, unscrew the Hex. valve cap at the top of the cylinder which is not delivering air, take out the sleeve, spring and ball. Wipe the valve seat with a small piece of cloth on the end of a match, after which, wipe off the ball and replace the parts.

When putting back the parts it will sometimes be necessary to put a small amount of white lead on the threads of the Hex. valve cap.

### Storage Tank

The storage tank of the Self-starter is carried beneath the body on the right hand side. This tank is tested for a pressure of 600 pounds to the square inch.

There are but three openings in the storage tank. From one of these a pipe leads to the pressure gauge on the dash (Fig. 15); another allows ingress and egress of compressed air for starting the motor; a third opening is the chain plug in the bottom of the tank, which should be removed every month or two to allow any accumulated moisture to escape. Connected with the main air line at the storage tank is a shut-off valve (Fig. 15), which should be closed at night or when the car is left standing for a long time. The handle of the shut-off valve projects through the heel board at the front of the driver's seat. The shut-off valve is merely a protection against small leaks in the starting mechanism.

### Dash Push Valve

The dash push valve (Figures 15 and 17 and Page 11) has a double function—opening the air line from the storage tank to the distributor, and opening the poppet valves in the cylinders.

Pressure upon the push button (Fig. 17) opens the valve (T) and allows air to escape from the storage tank through a pipe (Fig. 15) to the distributor. Simultaneously the dash valve button opens the cylinder valves (Fig. 15) so that air, coming from the distributor through the pipes shown in Figure 15 has ready access to the cylinders.

When the foot is removed from the dash button, both the escapement valve and the cylinder valves are closed automatically and the compressed air starter is shut off from the motor.

### Distributor

The function of the distributor (Fig. 16) is to send charges of air into the cylinders ready for the working stroke, in their order of firing. The distributor is geared to the pump and magneto shaft and positively timed, so that the charges of compressed air are fed to one cylinder at a time.

The distributor (Figures 15 and 16) consist merely of an air tight case in which operates a small gear-driven disc (W). This disc is bolted to its shaft and rotates on a bronze seat (V Fig. 16). As the disc revolves, the air above it passes through the slot (Fig. 16) into one of the four holes beneath the disc and thence to the proper cylinder, which is ready for the explosion stroke.

The distributor disc revolves idly, except when the motor is starting, at which time it distributes the pressure of air from the storage tank until the motor takes up regular firing.



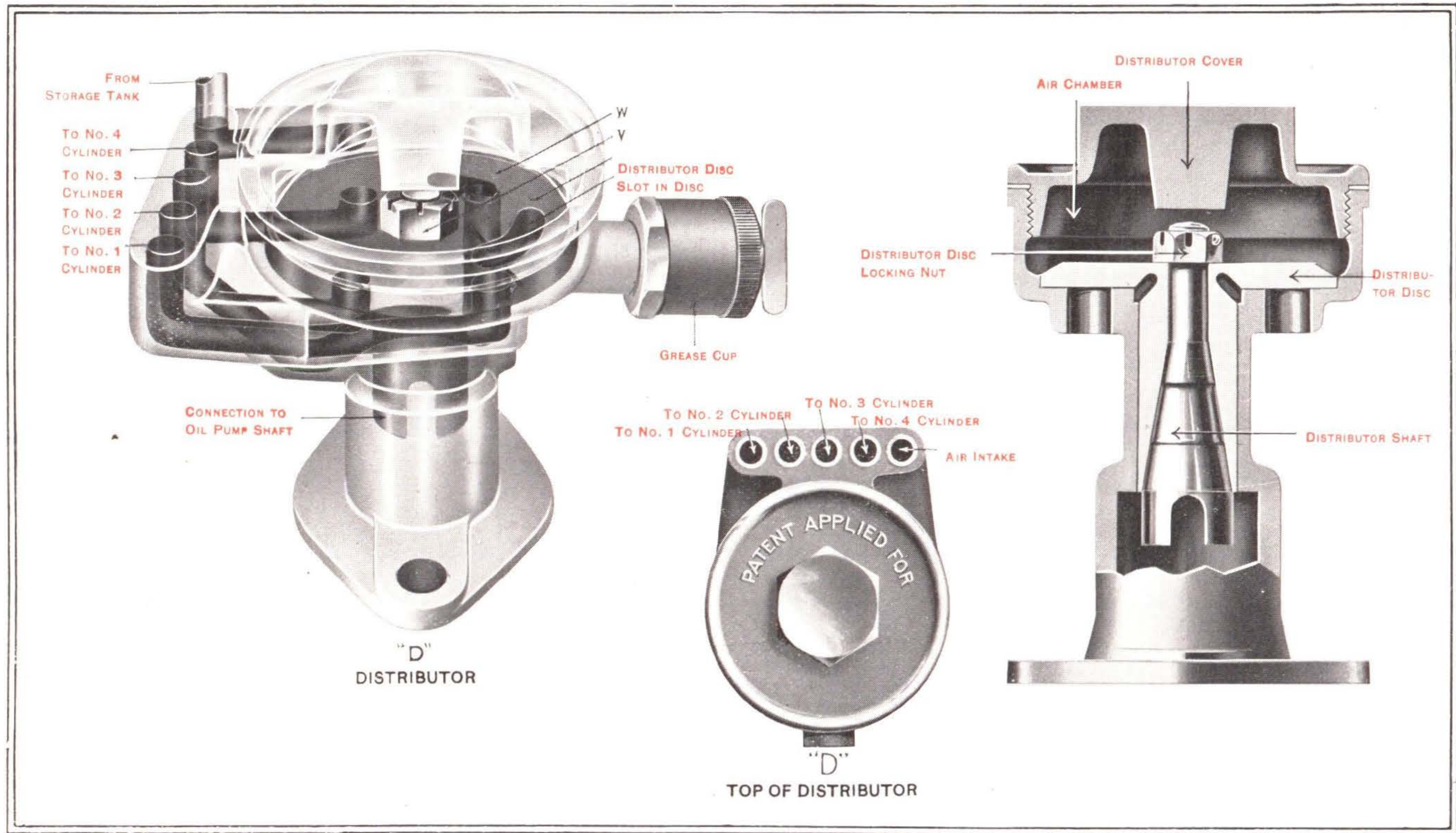

Fig. 16—Diagrammatic View of Self-starter Distributor



## Cylinder Valves

The purpose of the cylinder valves (Figures 15 and 17) is to prevent the escape of cylinder compression into the Self-starter system during the regular operation of the motor.

As the button of the dash push valve is depressed, a bar (Figures 15 and 17) opens the four cylinder valves by depressing a small lever, pushing down the valve stem and raising the valve proper from its seat. This operation gives the air charge an uninterrupted passage from the distributor pipe directly into the cylinder.

## Self-starter Connections

All of the pipes used in the construction of the Chalmers Self-starter are copper. The connections are simple and need be inspected only when the operator notices loss of compression in the storage tank. The air line connections occasionally should be tightened to insure against loss of compression.

## Operation

To start the motor with the Self-starter, advance throttle lever about one inch from base of quadrant; set spark lever about 3 inches up quadrant; turn ignition switch on dash to point marked "B." Then push dash button of Self-starter firmly with the foot. Keep foot on push button of Self-starter until explosions occur in the motor. Remove foot from Self-starter button; throw ignition switch on dash over to point marked "M;" advance spark lever two-thirds of the way up quadrant; retard throttle lever to point where motor does not "race."

If it is desired to start on magneto, set throttle lever about one-half inch from bottom of quadrant; advance spark lever two-thirds of the way up quadrant; turn dash ignition switch to "M." Then push dash button of Self-starter with the foot. When starting on the magneto, it will be found necessary to keep air valve open longer than when starting on the battery.

Close throttle entirely before stopping motor.

Note—When starting in cold weather be sure carburetor adjustment is set for rich mixture. (See pages 24 and 59.)

## Care of Starting Mechanism

To keep the Chalmers Self-starter in the best working condition, all leaks should be prevented.

Loss of pressure in the storage tank when the Starter is not in use, indicates a leak. Such loss will be registered by the pressure gauge on the dash. The leaking joint should be located at once and tightened. To locate a leak, simply rub a moist sponge over a cake of soap; then rub the sponge over the starter connections. The presence of a leak will be indicated by a bubble.

Once or twice each season the cylinder valves should be removed and lightly re-ground. To take out a valve, remove the bar connecting with the dash push button, then unscrew the valve.

The distributor should require no attention whatever. Screw down the grease cup (one complete turn) once or twice a week.

**Important: Keep all joints and air lines tightened.**



## Tire Inflator

A hose long enough to reach each of the tires and a special valve are provided in connection with the Chalmers Self-starter for the purpose of inflating tires.

To inflate tires: First, attach hose to special shut-off valve (Fig. 15) under the hood near the dash at the right side of the car. Fasten other end of hose to tire. Open shut-off valve until tire is inflated with the proper pressure. Be sure to close shut-off valve before removing hose.

It is not necessary to change the position of the shut-off handle which projects through the heel board of the dash. It makes no difference whether this valve is open or closed when inflating tires.

Note—Should there not be enough pressure in the storage tank to inflate the tires, start the motor in the usual way, then throw in the pump clutch and allow the air pump to increase the pressure in the tank.

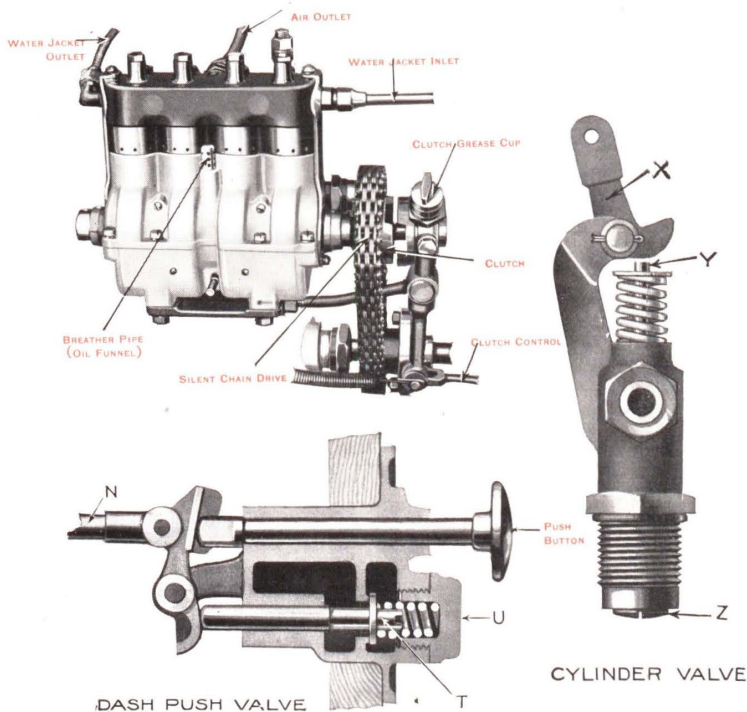

Fig. 17—Air Pump, Cylinder Valve and Dash Push Valve of Self-starter



# Electric Lighting System

The lighting system used on Chalmers cars is known as the Gray & Davis dynamo system.

This lightning system is extremely simple and will require practically no attention.

## General Principles

The purpose of this system is to furnish current for the head, side and tail lamps, and for the interior lights and step lights in the case of the enclosed cars.

When the car is in motion, electric current is generated by a dynamo (Gray & Davis type G). When the car is standing still, current is furnished by a storage battery carried on the right running board. In addition to the dynamo and storage battery, the system consists of the necessary wires and the dash set—an automatic cutout to take current from the dynamo or the storage battery as may be required; an ammeter which registers the amount of current generated by the dynamo; and a lighting switch.

## Dynamo

The Gray & Davis dynamo (Fig. 18) is of the constant current compound wired type. At speeds varying from 10 to 12 miles an hour, the dynamo voltage largely exceeds the battery voltage, so that from 10 miles an hour upward current is furnished to the wire by the dynamo. During the day, when the lights are not in use, the dynamo furnishes current to charge the battery at all variations of speed above 10 miles per hour.

The only attention which the dynamo will require is lubrication. There are four ball bearings that should be lubricated at least every 5000 miles. The main bearing, which takes all the driving strain, can be lubricated without opening the dynamo case. Take out the set screw and inject lubricant with an oil gun. Be sure to replace set screw. To lubricate the inner bearings, proceed as follows: Remove dynamo cover. Take out bearing screws. Inject high-grade non-fluid oil to bearings by means of a small grease gun. Replace bearing screws, being sure to see that all are tight.

While lubricating bearings, oil the dynamo governor pins. Replace dynamo cover.

Complete directions for care of dynamo may be secured from the Gray & Davis instruction book which will be provided by Gray & Davis, Boston, Mass., upon request.

## Adjusting Output of Dynamo

Under ordinary circumstances, it will be unnecessary for the operator to change the output of the dynamo. All dynamos are tested and adjusted to carry 8.5 amperes at 10 miles an hour and upwards.



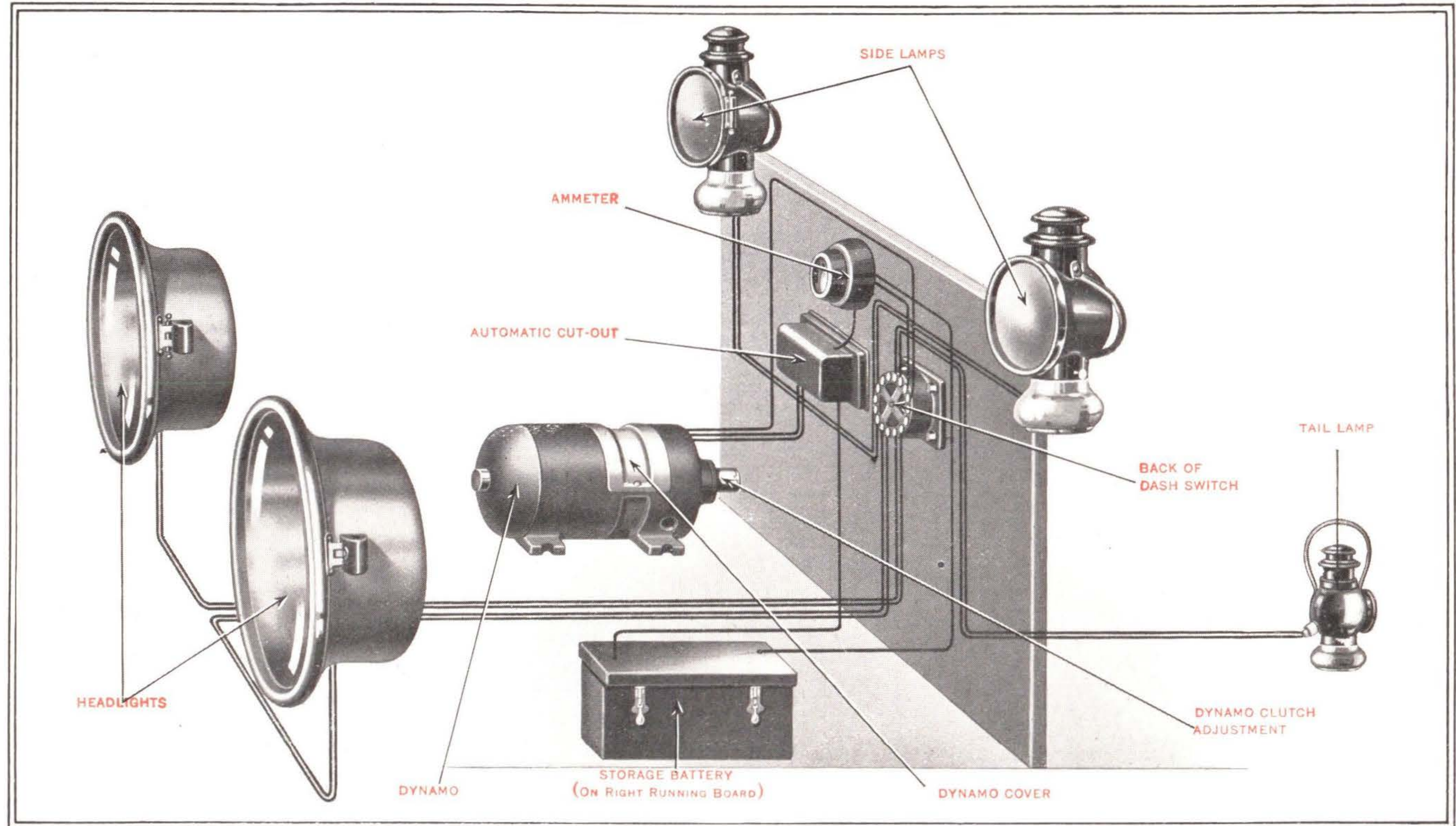

Fig. 18—Electric Lighting System of Chalmers "Thirty-six"



If, however, the lamp equipment of the car is greater than 8.5 amperes, more current will be needed. Or, if the daily running is greatly in excess of the night running, less current may be needed.

To change output of the dynamo, proceed as follows:

Remove dynamo cover. Turn governor shell until hole in shell lines with slotted end of rod "A" (Fig. 19).

To increase the current generated by the dynamo, turn adjusting nut in rod "A" (Fig. 19) to the right; i. e., tighten adjusting nut.

To decrease the current generated by the dynamo, turn adjusting nut in rod "A," to the left; i. e., loosen adjusting nut.

Do not make more than one complete turn of the adjusting nut before testing the lighting system. If one turn is not sufficient, make another slight adjustment and test again.

Be sure driving belt is tight at all times. The driving belt can be adjusted by moving fan lever up or down.

### Cutout

Do not tinker with the cutout. Ordinarily the cutout will require no attention. Failure of the cutout to work is shown by the ammeter indicating at the left of the zero mark or not indicating at all when the dynamo is generating. Do not attempt to adjust the cutout yourself. If it is not in working order, see your local representative of Gray & Davis or a Chalmers dealer.

### Battery

All storage batteries require attention in order to keep them in proper condition. Evaporation and lowering of the solution should be compensated for by adding distilled water—not acid—or electrolyte to the cells to bring the solution up to the level of the inside cover. Spilled solution should be compensated for by adding electrolyte or battery solution, which is composed of one part pure sulphuric acid and three parts water.

If the battery is left standing for a long time, it is best to take it at once to an expert and have it put in proper condition.

When batteries are not to be used for a long time, empty the solution, fill the battery to the inside cover with distilled water, and store in a dry place.

### Focusing

The electric head lights must be focused accurately to give the best results.

To focus Chalmers headlights set the car (after dark) in such a position that there is room to throw the light ahead for 300 or 400 feet. Throw a coat, or some other material through which the light will not penetrate, over one of the headlights. If the light thrown by the other lamp is not in focus, open the headlight door, take hold of the socket supporting the lamp, press the little spring that holds it in



place and the lamp may be moved forward or backward until the proper focus is obtained.

The best method of setting a focus depends upon the individual driver. Chalmers headlights can be focused so as to throw a spot light in the distance, but if they are set just a shade out of focus the light will be diffused close to the car.

Some drivers prefer to have one of the lamps throw a spot light and the other a diffused light.

If the lamps are burning brightly and at the same time the light is not good, it is generally an indication that the lamps are out of focus.

## In General

Do not attempt to take the Gray & Davis electric lighting system apart. While this system is extremely simple, electric systems in general are little understood by laymen and it is best not to experiment with them. Exhaustive tests have proved that the operator will have practically no trouble with the Gray & Davis electric lighting system. Adjustment of any of the parts will very rarely be required. If for any reason any of the lights of the car will not light, when the switch is turned on, proceed as follows:

First, look for a loose wiring connection. If you do not find a loose connection anywhere—

Second, take your car at once to your local representative of Gray & Davis or to a Chalmers dealer. Do not complicate matters by trying to do any work which you do not thoroughly understand.

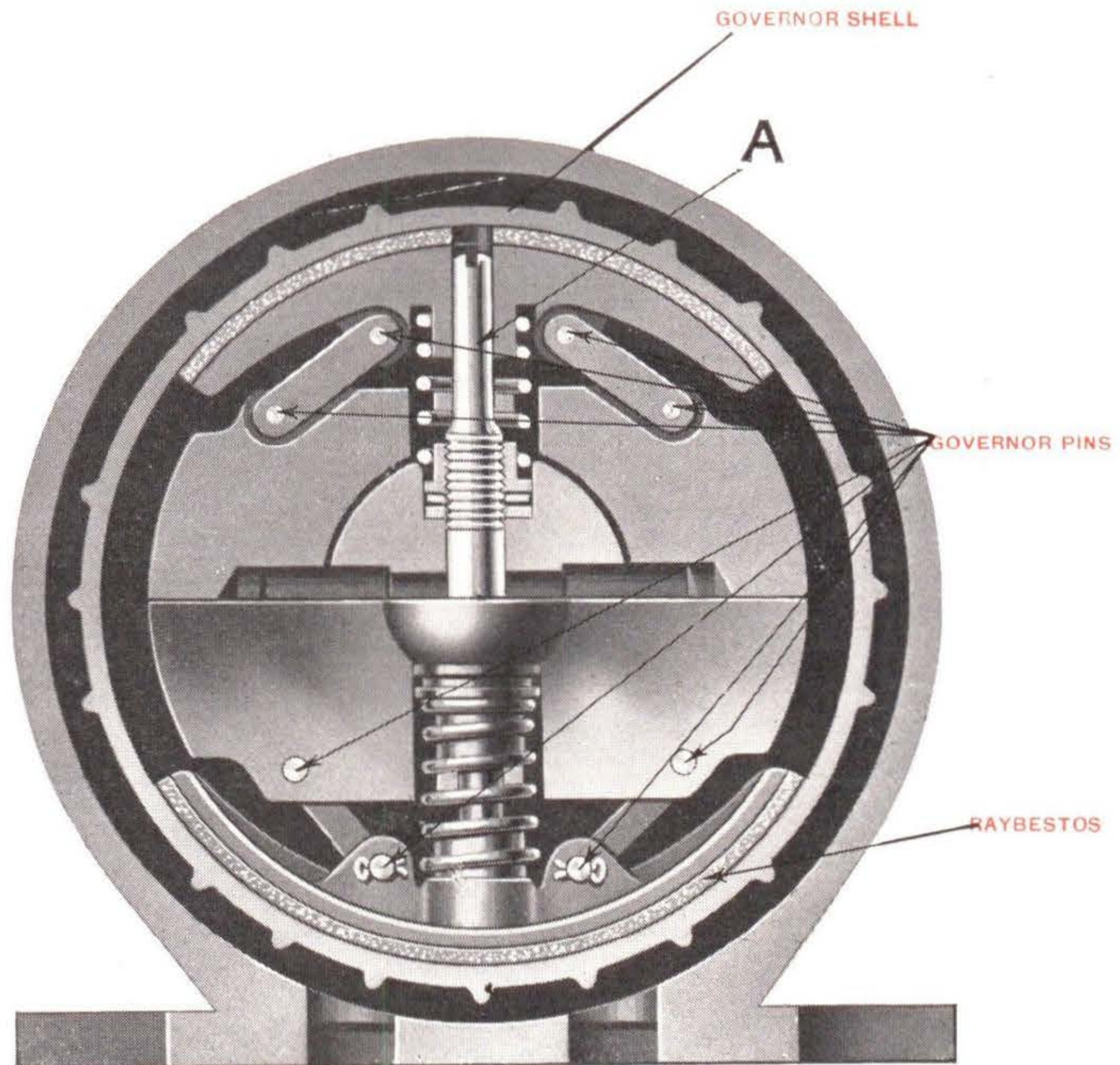

Fig. 19—Cross Section Through Dynamo Governor



# Proper Care of Motor

## Running a New Motor

Do not under any circumstances run a new motor at high speed for very long. Do not race the motor unnecessarily. This is very hard on the mechanism and there is never any reason for it.

## Maintaining Compression

It is important that the compression in all of the cylinders should be equal and be up to the proper standard. Faulty compression may be shown by loss of power or missing of motor.

Compression should be tested occasionally by turning the starting crank (with switch turned off) until resistance is felt in each of the four cylinders successively. Compare the resistance of each of the cylinders.

If the compression of one cylinder is less than the others, or if all are weak, the valves may not be seating properly: (1) on account of too little clearance between the valve stems and the valve tappets (See below); or (2) because there is a small deposit of carbon on the face of the valve.

Either of these faults may be quickly remedied. If they do not exist, the valves need cleaning.

## Cleaning the Valves

Leaky valves should be ground to fit properly in their seats, using some prepared valve grinding paste or a mixture of oil with fine emery powder or ground glass.

To grind the inlet valves: disconnect the "rocker arm" (Fig. 20, Page 54) by pressing down hard on one end of it and lifting the "push rod" clear of the valve tappet. Loosen rocker arm fulcrum lock nut; turn rocker arm to left. By unscrewing the large "inlet valve cage nut" (Fig. 11, Page 36) the inlet valve and cage may be lifted out. Loosening the inlet valve cage nut also releases the brass "inlet valve spring jacket." Force down the "spring washer" and remove the "locking clip." The washer is then free to slip over the end of the stem and the valve can be removed from the cage by taking the cotter pin from the valve stem.

When valve is reassembled be sure cotter pin is in place.

To remove the exhaust valve: first unscrew the "exhaust valve bonnets" (Fig. 11, Page 36). While holding the valve down from above, lift the "spring washer" (Fig. 20, Page 54) with the valve lifting tool provided for that purpose and remove the locking clip. The valve may then be lifted out without trouble.

Clean the valve, noting also whether the stem is clean and in good condition. Stuff rags or waste into the exhaust passage between the valve and the cylinder to keep grinding material out of the latter. Replace the valve upon its seat; with piston at beginning of firing stroke, and grind by rotating with a screw driver with a grinding paste between the valve and the seat. The valve should be ground until it has an even bearing all around its face. Carefully remove all the grinding compound and waste. Wash out the valves and cylinders with gasoline when through grinding.

## Valve Timing

The time and amount of opening of the valves depends upon the adjustment of the valve tappets (Fig. 20) which must bear upon the cams of the cam shaft (Fig. 11, Page 36). To adjust the timing, proceed as follows:



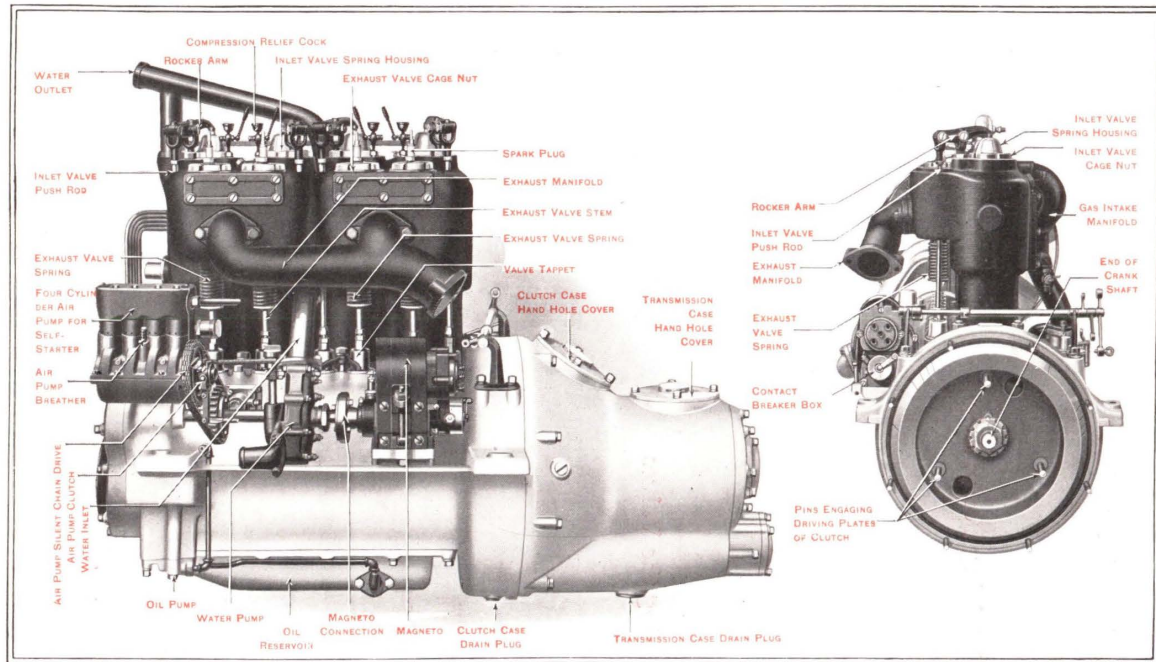

Fig. 20—Exhaust Side and Rear of Chalmers "Thirty-six" Motor



Remove the hand hole cover of clutch case (Fig. 13, Page 40). This will reveal the beveled rear edge of the flywheel, with its markings. Crank the motor until the exhaust valve of cylinder number one just closes. This point is reached when you are just able to turn the "valve tappet" under the "valve stem" with your fingers.

At this point, the mark "Ex. Cl." (exhaust closes) on the flywheel should be exactly centered with reference to the opening in the clutch case. If the closing is not correct, rotate the flywheel to bring this mark directly on center and adjust the valve tappet so that it will be just freeing itself at this point. This adjustment is made by loosening the "lock nut" and screwing the "adjusting screw" up and down (Fig. 20).

Turn the flywheel a short distance in the same direction, bringing the mark "In. Op." (inlet opens) to the center with reference to the hand hole opening. With flywheel mark in this position, the inlet valve on number one cylinder should just start to open. If not, adjust inlet valve tappet as described above. This operation should be repeated for each cylinder.

## Carbon in Cylinders

If the motor knocks when the spark is not retarded, and keeps on firing after the ignition switch has been turned off, and does not seem to develop the normal amount of power, it is probable that the cylinders have become carbonized.

This can be prevented by the regular use of kerosene. Pour two or three tablespoonfulls of kerosene through the "compression relief cock" (Fig. 21) into each cylinder once a week when the motor is warm, and let stand over night. This will remove a large part of the carbon and improve compression.

About once in three weeks, after carrying out the above instructions at night, repeat the dose in the morning.

An even better liquid than kerosene to cut carbon is a mixture of one-fourth alcohol and three-fourths kerosene. This should be put in through the relief cocks only.

If treatment with kerosene does not remove the carbon, it will be necessary to scrape the carbon from the piston heads and walls of the combustion chambers.

Do not use patent carbon removers that contain injurious acids.

## To Remove Carbon

Remove inlet valve cages, as for cleaning valves. Scrape carbon from walls of combustion chambers and piston heads with a blunt instrument. Use a piece of tin or a soft knife. Never use a hard steel scraper which will scratch the walls of the combustion chambers.

After removing carbon, clean combustion chambers with kerosene. Always remove carbon and grind valves at same overhauling. Remove carbon before grinding valves.

## Adjusting the Connecting Rod Bearings

These are practically the only bearings in the car that require any adjustment. This work should be done by a Chalmers Dealer. If it should be necessary to do the work yourself, proceed as follows:

Drain the oil from the crank case by removing the plug. (Fig. 10, Page 34.)

Remove the oil reservoir from beneath the motor, thus exposing the interior of the crank case. (Fig. 11, Page 36.)

After loosening the "connecting rod bolts," one or more "liners" (thin metal strips) may be removed from beneath the "bearing caps" until the proper adjustment is reached.

Be careful not to make the bearings too tight.



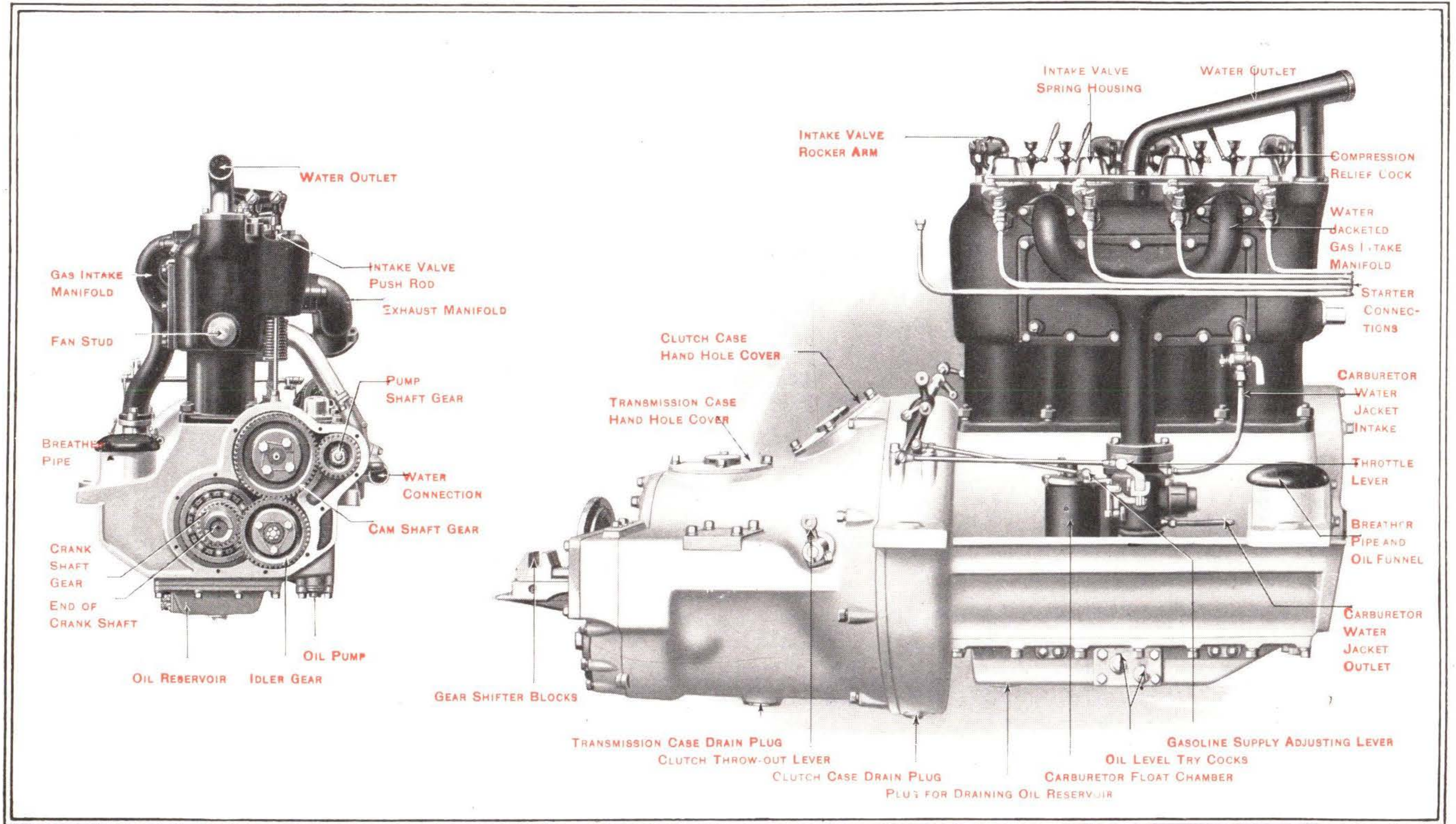

Fig. 21—Intake Side and Front of Chalmers "Thirty-six" Motor



# Running Gear

## Service Brakes

The service brakes—so called because they are controlled by the foot pedal and are the brakes generally used—are on the hubs of the rear wheels. (Fig. 12, Page 38.) These brakes are of the contracting type, consisting of a steel band lined with asbestos. All ordinary adjustments of the service brakes are made by means of a lock nut adjustment at the front of the brake band. (Fig. 22, Page 58.)

The steel brake bands can be relined readily when necessary by cutting off the old rivets and applying new lining.

## Emergency Brakes

The emergency brakes, or hand brakes, are also placed on the hubs of the rear wheels. They are of the internal expanding type and are lined with asbestos. The emergency brakes are operated by a hand lever operating on a toothed quadrant. (Fig. 14, Page 42.)

Both service brakes and emergency brakes operate on pressed steel brake drums.

Adjustment of the emergency brakes is made by shortening or lengthening the two brake pull rods by means of the threaded "brake pull rod adjustment." (Fig. 1, Page 12.)

In adjusting brakes, care should be taken to see that both brakes of the same set are adjusted evenly, so as to apply the same resistance to each of the rear wheels.

## Using the Brakes

Apply the brakes gradually. This is not only easier on the brakes, but saves the tires and applies the minimum strain to the car.

When slowing down the car or stopping, rounding corners or approaching crowded traffic, reduce speed as much as possible by closing the throttle. Then apply brakes. Do not throw on the brakes unnecessarily when car is moving fast.

When descending steep hills, lessen strain on emergency brakes by shifting gears into lower speed, letting in the clutch and allowing the motor to run with spark only slightly advanced. In this way, the motor itself will serve as a brake, as car cannot run faster than motor in running.

## Steering Gear

The steering gear is of the worm and gear type. (Lubricating directions on Page 13.)

Adjustment of the steering gear is required only at long intervals and should, if possible, be made by a Chalmers Dealer. There are only two points which can require adjustment: (1) the bearing at the point where the steering post enters the steering gear case (Fig.



1, Page 12). Should end play of the steering column develop, screw adjusting nut down a little and lock in place by the locking spring. (2) Adjustment of the bearing on the "ball arm shaft" takes up lost motion in the steering gear. To adjust this, it will be necessary to remove steering gear from the car.

Do not adjust steering gear unless you are sure trouble is there. Look at reach rod adjustments.

The exterior steering connections, including the various joints between the reach rod, steering knuckle, cross rod, etc., (Fig. 1, Page 12) frequently should be inspected, kept in good condition and properly lubricated.

## Spring Clips

Tighten up the spring clips hard and often to avoid spring breakage.

The object of the spring clips is not only to hold the springs firmly to the axle, but also to prevent movement of the spring leaves between the clips. Breakage of springs at the middle is caused almost entirely by loose spring clips. When the car is new, spring clips should be examined and tightened every day until the stretch of the metal has been taken up. After this, clips need be examined no oftener than once a week.

## Spring Hangers

Keep hangers well greased and tight. (Fig. 1, Page 12.)

See that the bolts work in the bearings of the springs and not in the hangers.

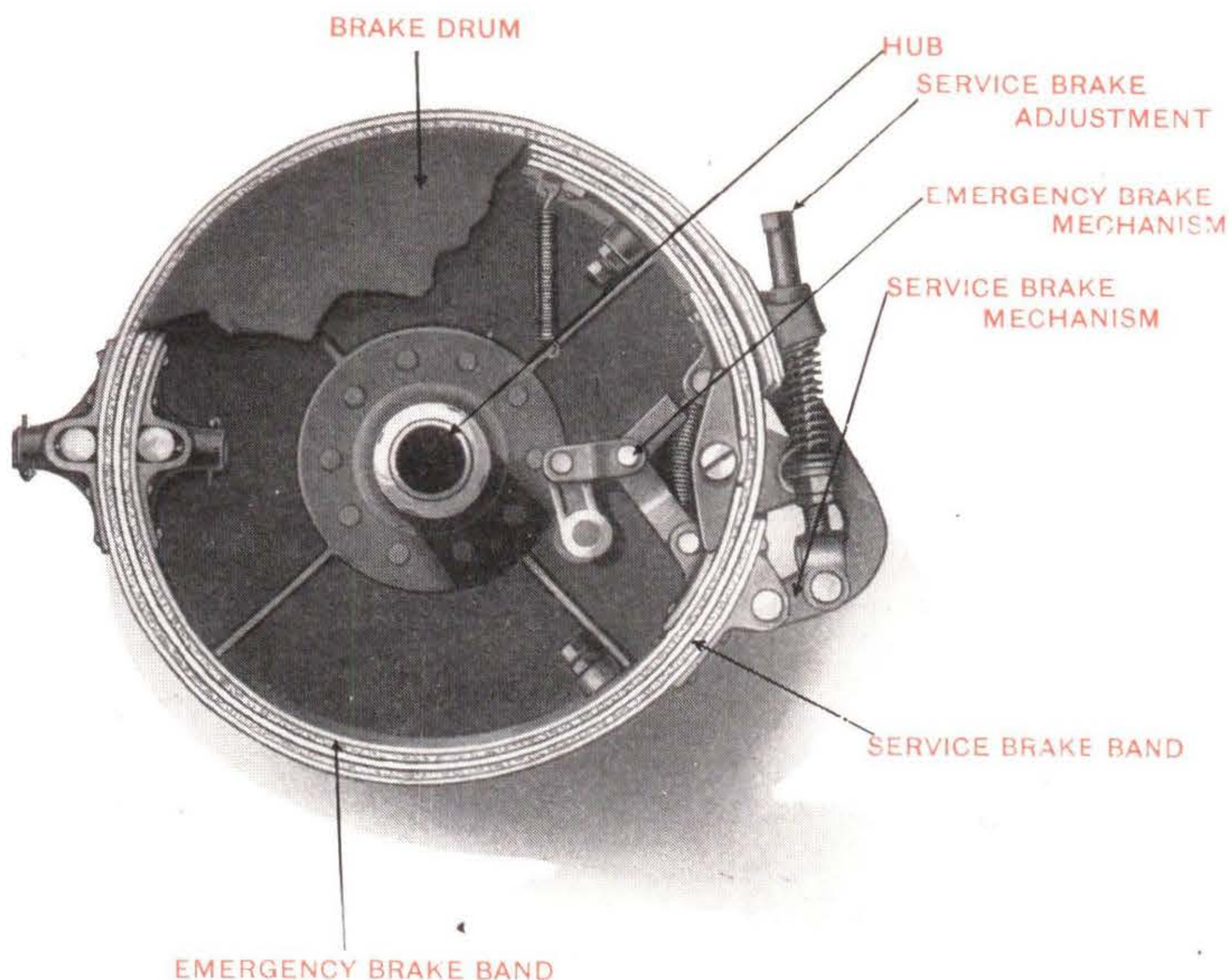

Fig. 22—Brake Construction of the Chalmers "Thirty-six"



# Cold Weather Procedure

## In General

When the motor is cold, gasoline vaporizes slowly, ignites slowly and burns slowly; hence to start a cold motor requires a richer mixture and earlier spark than when the motor is warm.

To insure a rich mixture, be sure the gasoline is of good quality and has no water in it; drain sediment cup at bottom of gasoline tank to get rid of water and sediment; be sure dash lever for adjustment of carburetor is moved over toward "R."

## Stopping the Motor

Close throttle entirely before shutting off motor.

## Starting the Motor

In extremely cold weather, prime the carburetor before starting motor. When this is done, less air pressure will be required. Adjust carburetor to feed an extremely rich mixture when starting.

## Draining the Car

If the car is not to be used during freezing weather, the water circulation system should be thoroughly drained.

Open the drain plug underneath the radiator. Remove the pipe plug from the bottom of the water pump and also the small plug in the water jacket cover. Open the cock in the carburetor hot water pipe. Radiator filler cap should be removed. Rock the body a few times to get out all of the water.

The motor may be started and run for a minute to evaporate any moisture remaining. Be careful not to run motor long enough to over-heat it, as there is no cooling water in jackets.

## Anti-Freezing Mixture

In freezing weather the water circulation system should be filled with one of the following anti-freezing solutions:

For a temperature not lower than 5 degrees below zero:

Wood Alcohol.....	15 per cent
Glycerine.....	15 per cent
Water.....	70 per cent

For a temperature not lower than 15 degrees below zero:

Wood Alcohol.....	17 per cent
Glycerine.....	17 per cent
Water.....	66 per cent

About 3½ gallons are required for the Chalmers "Thirty-six."

Alcohol should be added occasionally to make up for evaporation.



# Troubles

## Important Advice

Do not touch any adjustments or tamper with any parts until you know what causes the trouble. Otherwise you may get everything out of adjustment. When in doubt, don't do anything. Sit down and analyze the problem.

## Motor Fails to Start

- (1) **Lack of Gasoline.**  
See that tank is full and shut-off cock is open. Is gasoline line free of clogs?
- (2) **Lack of ignition current.**  
This may be due to neglect to turn on switch, run-down storage battery, broken or disconnected wire.  
Lack of ignition current is shown by failure of the coil to buzz when the spark lever is moved to different positions around the quadrant.
- (3) **Dirty spark plugs.**  
These are due to excessive amount of oil in the motor and to long use whereby the points become coated with carbon. Dirty spark plugs should be removed and cleaned.
- (4) **Motor on Dead Center.**  
Turn crank two or three inches from right to left. Try Self-starter again.

## Motor Stops

- (1) **Lack of gasoline.**
- (2) **Disconnected switch or wires.**
- (3) **Short circuiting of magneto ground-wire.**
- (4) **Lack of oil.**

## Motor Misses

- (1) **Weak battery.**  
Shift at once to magneto.
- (2) **Broken or disconnected wiring.**  
Shift to the other ignition system to see whether cylinders fire properly on it.  
If the motor misses, short circuit the spark plugs, one after another, by touching a hammer or screw driver from the metal of the cylinders to the terminals of the spark plugs. When one is reached which makes no difference in the running of the engine, this is probably the plug at fault.  
Be sure magneto secondary terminals do not touch at distributor.
- (3) **Dirty spark plugs.**  
Remove and clean. Be sure porcelain insulation is not cracked.
- (4) **Points of spark plugs improperly set.**  
If these points are too close together or too far apart, missing may result. Spark plug points should be set a scant 1-32 inch apart, about the thickness of a dime.
- (5) **Defective carbureter adjustment.**  
See page 24.
- (6) **Loss of compression in any cylinder.**  
Valve may be stuck or there may be dirt under it. Examine the valve tappet to see whether the valve seats properly. To locate cylinder that is weak on compression, turn over the motor by hand, testing each one in turn. See page 53.
- (7) **Air leak around inlet valve cage.**  
Can be detected by putting oil or water around the inlet valve cage nut. (Fig. 11, Page 36.)



- (8) **Water in gasoline.**  
Indicated by motor running and stopping and running again, by fits and starts.

### Motor Overheats

- (1) **Lack of proper lubrication.** See page 13 and page 35.
- (2) **Defective water circulation.**  
Inspect all water passages, making sure that the gaskets (washers) at flanged joints have not swollen in such a way as to cut down the opening.
- (3) **Running with open throttle and retarded spark.**  
The spark lever should be kept as far advanced on the quadrant as possible without causing the motor to knock. This saves fuel besides avoiding overheating.
- (4) **Slipping fan belt or bent fan plates.**  
Belt should be tightened and plates bent to the proper angle.
- (5) **Too much gasoline.**  
Too rich a mixture is indicated by black smoke at the exhaust. The motor will sometimes continue to fire after the switch has been turned off, even though the water is not hot enough to indicate overheating.  
This firing is caused either by a carbon deposit in the cylinders, which becomes incandescent, or by some metallic edge or point within the combustion space which becomes red hot. Such sharp points should be located if possible and smoothed down. For carbon in cylinders, see page 55.

### Motor Knocks

- (1) **Connecting rod bearings too loose.**  
Loose bearings give a light knock at high speed. If you are sure that faulty bearing adjustment is the cause of the trouble, it is best to have these bearings adjusted by a Chalmers dealer. If you do it yourself, directions will be found on page 55.
- (2) **Carrying the spark too far advanced.**  
See above under "Overheating."
- (3) **Lack of proper lubrication within the motor.**  
See page 13 and page 35.
- (4) **Faulty carburetor adjustment.**  
See page 25.
- (5) **A loose piston in one of the cylinders.**  
Remedying this trouble should by all means be intrusted to a Chalmers dealer.
- (6) **Carbon in cylinders.**  
This carbon becomes heated and may cause premature ignition. For cleaning cylinders, see page 55.
- (7) **Motor speed too slow when pulling up hill on direct drive.**  
Shift into second speed.
- (8) **Crank shaft bearing loose.**  
Heavy pound at slow motor speed under heavy load. The adjustment of this bearing will have to be made by a Chalmers dealer.
- (9) **Dirt or a broken ball in crank shaft bearing.**  
Proper lubrication with good oil will prevent dirt in bearings. A broken ball is an exceedingly rare possibility.

### Motor Will Not Stop

- (1) **Open circuit in switch.**  
Disconnect the battery wire, or "ground" the magneto by touching a screw driver to "breaker box" and frame at the same time.



(2) The wire connecting magneto and switch may be disconnected. "Ground" the magneto as above.

(3) Overheating.

Motor runs with some pounding and slowly. Close throttle completely. See above under "Overheating."

## Loss of Power

The motor will run, but will not pull the car under a heavy load. May be due to:

Loss of compression.

Too rich a mixture, through carburetor flooding.

Valves not seating properly and not holding compression.

Weak ignition.

Lack of oil or water.

Lack of gasoline.

If this is due to stoppage of the gasoline pipe, the motor will spit back through the carburetor when the throttle is open.

Dragging brakes.

See if the car can be rolled by hand easily, or if it will coast down hill with clutch released. Feel the brakes to see if they are hot.

Flat tire.

## Clutch Slips

A slipping clutch can be detected by the engine's running away from the car when the throttle is open.

For remedy, see page 39.

## Clutch Grabs

If the clutch takes hold too suddenly this may be due to:

(1) Lack of proper lubrication of clutch.

(2) Too tight adjustment of clutch springs. For remedy, see page 39.

## Lack of Good Compression

This is generally due to leaky valves. These should be adjusted or reground. See page 53.

A very likely place for loss of compression is around the inlet valve cage. This can be remedied by washing the seat in the cylinder head, and seeing that the copper gasket (washer) is in good condition. Be sure that the "inlet valve cage nut" (Fig. 11, Page 36) is tight.

## Popping Back Through Carburetor

This usually indicates too weak a mixture and may be caused by:

Faulty supply valve adjustment.

Dirt in gasoline passage or nozzle.

Air leak in the intake passage or around the inlet valve cage.

Inlet valves holding open.

Water in the gasoline.

Excessive temperature of the water jacket of the carburetor, especially in hot weather. This can be remedied by shutting off the water from the carburetor jacket.

## Squeaks

Squeaks in the motor and running gear are generally due to lack of lubrication, which should be remedied at once.

If the springs squeak, pry the leaves apart and apply graphite grease between them. See page 14. See that all nuts and bolts are tight—especially spring clip nuts.



# Driving Suggestions

## Starting

In starting an automobile, the object to be striven for is to have the car pass from a stationary position into rapid motion with a minimum of strain on the motor and other parts. A skillful driver aims to create a steady pull on the driving mechanism from the moment he begins to slip into first speed until the car is under full headway.

Starting with a jerk or passing unevenly from one speed to another, strains the motor, racks the frame and causes various troubles in the driving mechanism. The proper way to start, after you have learned the rudiments of gear-shifting, is as follows:

Having started the engine, with the gears in neutral, throw out the clutch, advance the spark lever two-thirds of the way up the quadrant, throw in first speed, let in the clutch gently and increase the motor speed gradually with the foot throttle or accelerator until the motor picks up the load of the car.

As you throw out the clutch to shift into second speed release the accelerator, thereby throttling down the motor. With the motor thus throttled and the clutch out shift to second speed, let in the clutch and again accelerate.

Repeat this operation in going into third and fourth speeds.

By throttling down the motor just before shifting gears you cause the two gears which are to be meshed to run at about equal speed. This permits a smooth shifting of gears and avoids racing the motor. More important than all, it creates a steadily increasing pull from the first application of power until the car is fully under way.

## Speeding

Upon receiving a new car do not allow your delight in the swift motion and easy control to run away with you. Above all do not get so enthusiastic that you take your car out on the road and run it at top speed. Wait until you are perfectly sure of your ability to drive.

Not only this, but wait until you have given your car a chance to settle. Any new piece of machinery, no matter how carefully adjusted or thoroughly tested in building, needs to be run awhile before it reaches its maximum efficiency. Give your bearings a chance to wear down to a nicety and all your working parts a chance to get into proper harmony.

Remember that a touring car is not a racing car.

Its oiling facilities are designed for touring and not for racing. A few miles of racing at top speed is harder on the bearings of a car than days or even weeks of steady touring at a reasonable speed.

## Hill Climbing

The wise driver will use his intermediate gears on steep hills even where he could climb them on high.

It is only the novice who wants to climb every hill on high.



If you watch the expert drivers who handle cars in endurance runs and other contests, they will teach you to use the intermediate gears on hills or heavy roads.

When approaching a hill which you see must be taken on high speed, get a good start on high and rush the hill—provided the road is good and you can see where you are going.

As soon as the motor begins to labor, shift at once to third or second speed, while the car still has good momentum. Don't let the car slow down.

## Bad Roads

In coming to a bad piece of road, full of ruts, bumps or holes, it is best to shift immediately into third speed, or second if necessary.

Thus you have much better control of the car, you can stop more quickly and can pick up more readily than on high gear. Using the lower speeds you can control the car almost entirely with the throttle, letting yourself down easily into holes and over bumps, without having to slip the clutch.

In going over abrupt bumps, high-water breaks or ridges, slow up and cross them obliquely instead of hitting them squarely.

This will break the jolt, because the springs receive the jar successively instead of all at once.

In going through sand it is better to let the car find its own traction rather than to use energy holding the car in line and forcing it to make a track for itself.

## In Traffic

In going through the crowded down-town streets of cities it is wise to use the third speed instead of attempting to run on high and continually shifting in tight places.

In coming to a crossing where he sees that he will have to stop, the good driver begins to slow down gradually instead of waiting until he is close to the crossing and then jamming on the brakes.

It is just as important to avoid straining the car in stopping as it is in starting. Smooth, easy starting or stopping saves tires.

## Skidding

In passing over wet pavements or slimy roads avoid sudden turns or changes of direction. Avoid also sudden application of the brakes.

To avoid skidding—when you feel the rear end of the car starting to slip, make a quick turn toward the same side and the car will right itself.

When a car starts to skid on account of the sudden application of the brakes or of the power, throw off the power or brakes and let the car coast free. In this condition the car will skid the least.



# Miscellaneous Suggestions

## Washing the Car

Great care should be exercised in washing the car, especially during the first few months that it is in use.

Varnish requires some time to season thoroughly, and while seasoning is easily affected. Gasoline or soaps injurious to varnish should never be used. Castile or Ivory soap is best for removing grease. Use plenty of lukewarm water and rinse the body thoroughly. Never use extremely hot or cold water for washing the body.

Mud should not be allowed to dry on the car if it is possible to avoid it. Use plenty of water to soak the mud off rather than rubbing it off.

For drying the car after washing, use a clean chamois skin.

It is better to remove a thick coat of dust by washing rather than by dusting. For ordinary light dusting, a woolen duster is preferable to a feather duster.

## Tires and Their Care

The tires should be kept pumped up hard all the time. A soft tire may ride easier, but will cause much tire trouble.

Soft tires are liable to punctures and blowouts.

Cuts in the outer casing should be promptly revulcanized to prevent water and dirt from working in and rotting the fabric. Never allow oil to remain on the tires as it rots the rubber.

Do not allow car to stand with tires in water.

If the car is allowed to stand for long intervals, it should be jacked up so that the weight will not rest on the tires.

In general, all tire troubles should be taken up directly with the tire makers.

## Don't's

Don't start on a trip without attention to oil, gasoline and water.

Don't go on an extended trip without testing your battery.

Don't fail to keep your brakes adjusted. It is more necessary to be able to stop the car than to start it.

Don't leave the car alone with the motor running.

Don't stop the car on the wrong side of the street.

Don't drive faster than the law allows.

Don't fail to release the hand brake before attempting to start.

Don't "jump" the car by quick opening of the throttle.

Don't forget, above all else, that an automobile is the finest piece of machinery in the world and that you will be repaid in excellence of service many times over for the care and attention given it.



## Index

	Page		Page
Accelerator pedal.....	26	Adjusting spark plugs.....	31
Adjusting brakes.....	57	"    steering gear.....	57, 58
"    carburetor.....	25	Anti-freezing mixture.....	59
"    clutch.....	39	Air intake shutters, carburetor.....	24
"    connecting rod bearings.....	55	"    pressure system.....	21
"    cylinder valves (Self-starter) ..	47	"    "    starter system.....	43
"    differential driving gear.....	42	"    "    gauge.....	43
"    gear shifting mechanism.....	42	"    pump, gasoline system.....	22
"    output of dynamo.....	49	"    "    starting system.....	43
"    Self-starter air pump.....	45	Auxiliary air valve, carburetor.....	25
"    "    mechanism.....	47		
Battery, charging.....	27	Bolts, tightening.....	15
"    coil.....	27	Brakes, service and emergency.....	57
"    current, action of.....	27	"    adjustment of.....	57
"    electric lighting system.....	51	"    inspection of.....	15
"    starting on.....	7	"    use of.....	57
Carbon, in cylinders.....	55, 61	Clutch, care of.....	39
"    how removed.....	55	"    slipping and grabbing.....	62
Carburetor, action of.....	24	Coil, battery.....	27
"    air inlets.....	24, 25	Cold weather procedure.....	59
"    auxiliary air valve.....	25	Compression, loss of.....	62
"    adjustment of.....	25	"    maintaining.....	53
"    float chamber.....	24	"    testing.....	15, 53
"    mixing chamber.....	24	Connecting rod bearings, adjustment of.	55
"    popping back through.....	62	Connections, self-starter.....	47
"    priming.....	25	Correspondence with Chalmers Company	6
Care of gasoline pressure system.....	22	Cranking, necessity for.....	8
"    "    magneto.....	29	"    motor, how done.....	8, 30
"    "    dynamo.....	49	Current, battery, action of.....	27
Changing speeds.....	9, 41	"    magneto, action of.....	30
"    to lower speeds.....	10, 42	Cut out, electric light system.....	51
Charging battery.....	27	Cylinder valves, self-starter.....	47
Clutch.....	39	Cylinders, carbon in.....	55, 60
Dash push valve, Self-starter.....	45	Distributor, Self-starter lubrication.....	13
Dead center, motor on.....	8, 60	"    magneto.....	29
Differential driving gears, function and adjustment.....	42	Distributor, magneto.....	29
Differential housing, lubrication.....	14	Draining old oil.....	14
Distributor, Self-starter.....	45	"    water system.....	59
Electric Lighting System.....	49	Driving suggestions.....	63
		Dynamo, electric lighting.....	49
Fan, how supported.....	33		
"    belt, how tightened.....	33	Focusing electric head lights.....	52
Fast running, increased lubrication for..	37	Foot and hand brakes.....	57
Float chamber, carburetor.....	24	Freezing, anti, mixture.....	59
Gasoline, gravity feed.....	21	Gear, running.....	57
"    pressure system.....	21	"    shifting lever.....	41
"    sediment cup.....	23	"    "    mechanism, adjustment of	42
"    shut-off cock.....	23	"    steering.....	57
"    system.....	21	Gears, speed changing, action of.....	39
"    tank.....	21	Grinding valves.....	53
Gear, differential.....	42		



## Index (continued)

	Page		Page
Hand and foot brakes.....	57	Hand throttle.....	25
" pump, pressure.....	21	Hill climbing.....	63
Ignition.....	27	Inspection of gear shifting mechanism... 15	
" premature.....	30	" " ignition system.....	15
" current, lack of.....	60	" " steering connections.....	15
Inflating tires.....	48	" " storage battery.....	15
Inspection of brakes.....	15	" " springs.....	15
" " car, semi-monthly.....	15	" " bolts.....	15
" " cylinders, for compression 15, 53		" " water circulation system.. 15	
Leaks, gasoline pressure system.....	23	Lubrication, increased for fast running.. 37	
" Self-starter.....	47	" insufficient.....	37
Lever, gear shifting, movements of.....	41	" importance of.....	35
Lower speeds, changing to.....	10, 42	" system.....	35
Lubrication, general directions for.....	13	Lubricants, recommended for Chalmers	
" motor, directions for.....	35	cars.....	35
Magneto.....	29	Motor, dead Center.....	8, 60
" care of.....	29	" four-cycle, principle of.....	17
" current, action of.....	29	" fails to start.....	60
" oiling.....	14	" loses power.....	62
" setting.....	29	" misses.....	60
" starting on.....	8	" new, running a.....	53
Mixing chamber, carburetor.....	24	" knocks in.....	55, 61
Motor, how started.....	7, 8	" over-heats.....	61
" necessity for cranking.....	8	" proper care of.....	53
" oiling the.....	13, 35, 36	" stops.....	60
" stopping the.....	11	" will not stop.....	61
" car, five systems of.....	19		
Oil, draining off old.....	14, 37	Oiling, increased for fast running.....	37
" in crank case.....	13, 35	" clutch.....	39
" pump.....	37	" motor.....	35
" reservoir.....	35	" transmission.....	13
" sight feed.....	37	Operation, general directions for.....	7
Oiling directions.....	13		
Pedal, accelerator.....	26	Pressure pump, Self-starter.....	43
Pedals, operation.....	8	Principle of four-cycle gasoline motor... 17	
Premature ignition.....	30	Pump, oil.....	37
Pressure, in gasoline tank.....	21	" hand.....	21
" gauge, Self-starter.....	43	" compression.....	43
" how secured.....	21	" water.....	33
" system.....	21	Push valve, Self-starter.....	45
" " care of.....	22	" button, Self-starter.....	8, 47
" in Self-starter tank.....	45	Poppet valves, Self-starter (See cylinder	
" pump, gasoline.....	22	valves).....	47
Radiator, filling the.....	33	Roads, bad, driving on.....	64
Repair parts, ordering.....	6	Running new motor.....	53
Reversing the car.....	11	" gear.....	57
Sediment cup, gasoline.....	23	Sight feed, oiling.....	37
Shifting gears.....	9, 39, 41, 64	Spark, timing the.....	30
Shut-off cock, gasoline system.....	23	Setting the magneto.....	29
" valve, Self-starter.....	43, 45, 48	Speed changing gear, action of.....	39
Skidding.....	64	" " procedure.....	41



## Index (continued)

	Page		Page
Speeding.....	63	Stopping the motor.....	59
Spring clips.....	15, 58	Steering gear.....	57
"    hangers.....	58	Squeaks.....	62
Springs, inspection of.....	15	Semi-monthly inspection.....	15
Starting car.....	8, 63	System, gasoline.....	21
"    motor on battery.....	7	"    ignition.....	27
"    "    on magneto.....	8	"    lubrication.....	35
"    "    in cold weather.....	59	"    power transmission.....	39
"    "    preliminary to.....	7	"    water circulation.....	33
"    system.....	43	"    compressed air starting.....	43
Stopping the car.....	10	Systems, the five of a motor car.....	19
Tank, gasoline.....	21	Tire inflater.....	48
"    storage, Self-starter.....	45	Tires and their care.....	65
Throttle, hand.....	25	Traffic, driving in.....	64
"    foot (accelerator).....	26	Transmission.....	39
"    valve.....	25	"    oiling.....	13
Timing the spark.....	30	Troubles.....	60
"    valves.....	45	 	
Valve, cylinder, Self-starter.....	47	Valve, throttle.....	25
"    dash push, Self-starter.....	45	Valves, cleaning the.....	49
"    hand pump pressure.....	21	"    grinding the.....	47
"    shut-off, gasoline system.....	23	"    timing.....	45
"    shut-off Self-starter.....	43, 45, 48	"    tire inflater.....	48
Washing the car.....	65	Water system, draining the.....	59
Water circulation system.....	33	Winter procedure.....	59
"    pump.....	33	Wiring, inspection of.....	15
"    system, cleaning the.....	33		